

TIG

Quick Start



1 Introducing Tig

- Tig is a miniature humanoid robot designed to enable simplified user-created programming and AI interactions.
- Tig features 8 Degrees of Freedom, providing dexterity to perform actions such as running, martial arts, and complex performances. Tig can also display various facial expressions on its LCD screen to reflect its mood.
- In addition, Tig can be programmed or remotely controlled using a PC or smart device, allowing users to control Tig anytime and anywhere.
- User-created Tig programs allow control over not only sounds, displayed images, and motion but also various AI functionalities including image recognition, motion recognition, voice recognition (STT), Text to Speech conversion, and translation.

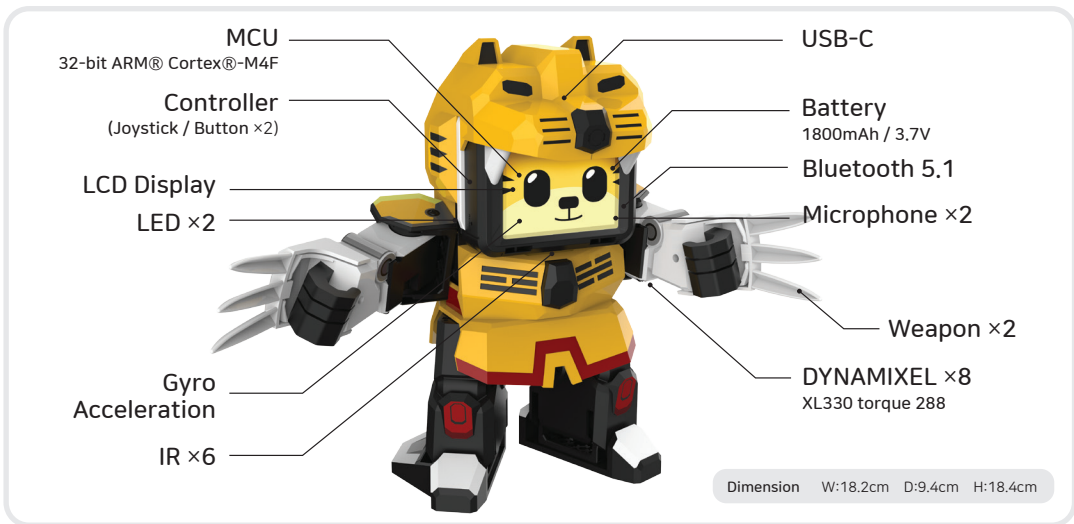

2 Introducing Tig Software

R-BLOCK

R-Block is a block-based programming tool available through the web and mobile application allowing users without previous programming experience to write programs for their robots. R-Block supports all of Tig's features, which include screen control, motion, Text to Speech, voice recognition, and translation.

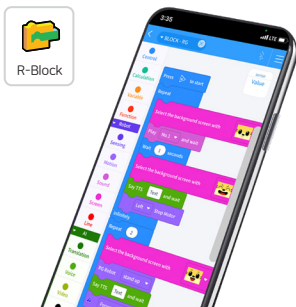

STEAMCUP

STEAMCUP is a community platform that provides a space for users to create and participate in customized contests, share their creations, and form community Circles with like-minded individuals. STEAMCUP also features built-in integration of ROBOTIS' R-Block and R-Motion robot programming tools.



R-MOTION

R-Motion is a motion-based programming tool available through the web and by mobile application allowing users to use a 3D model of their robot to create programs for their physical robot. R-Motion offers many editing features to simplify the creation of custom motions. Some of its features include bilateral mirroring, customized poses, and adjustable motion execution speed.

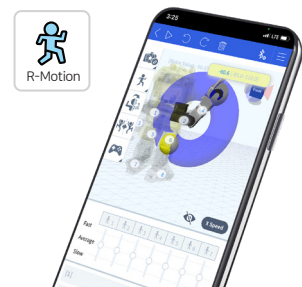

3 List of Components

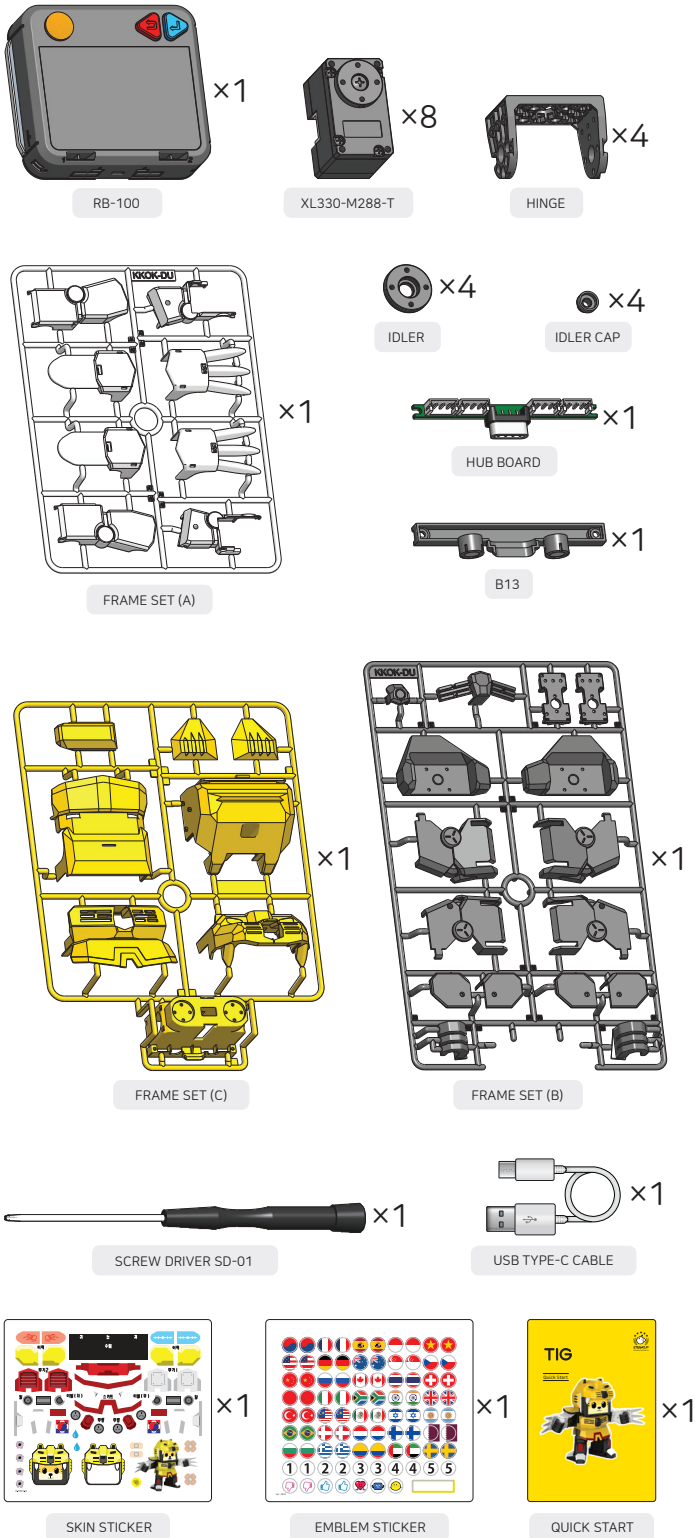

1:1 SCALE

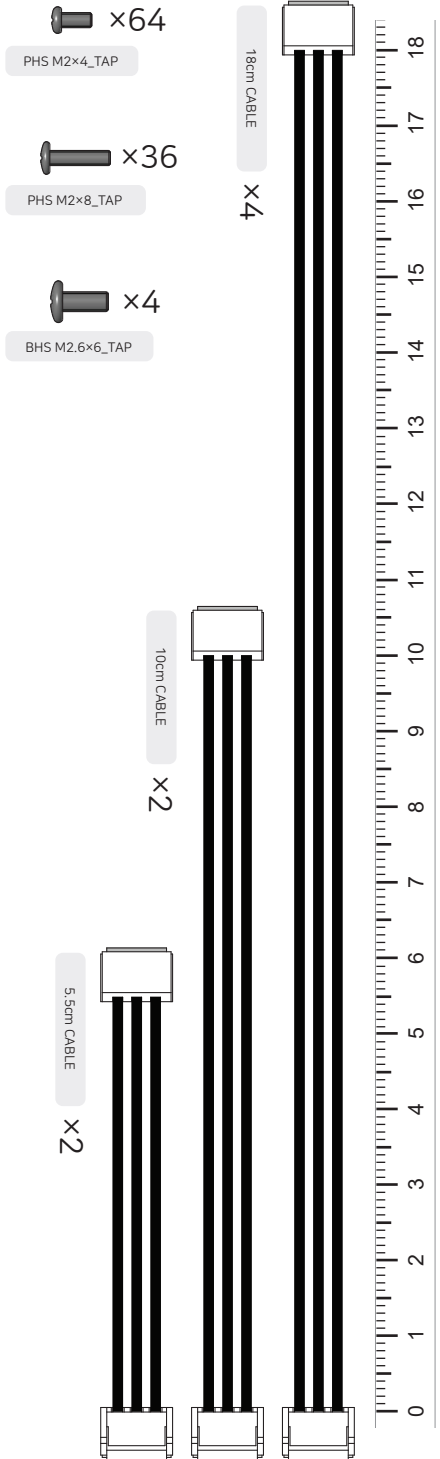

* The components and colors included in your kit may differ slightly from the image above.

4 Assembly Guide

 This kit contains sharp tools, such as a screwdriver. Adult supervision is required for assembly.

1

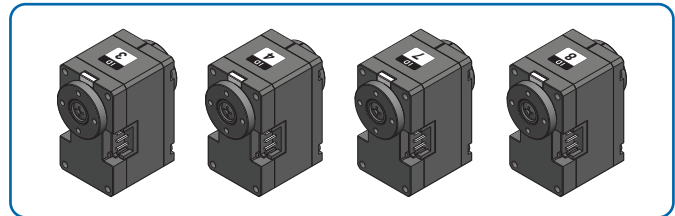
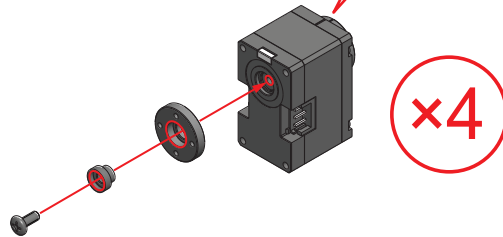
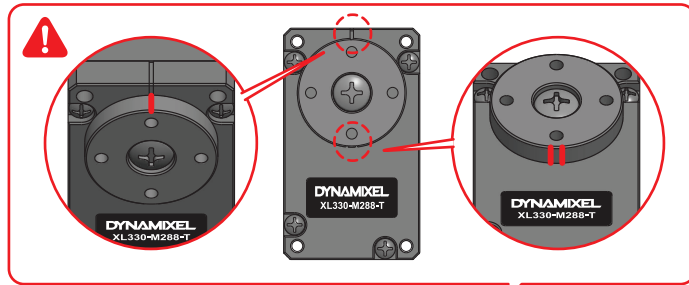
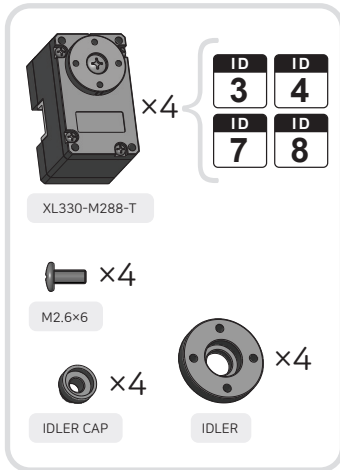

2

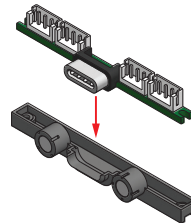
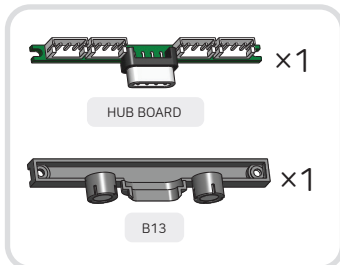

3

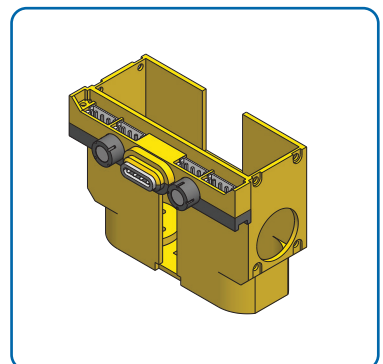
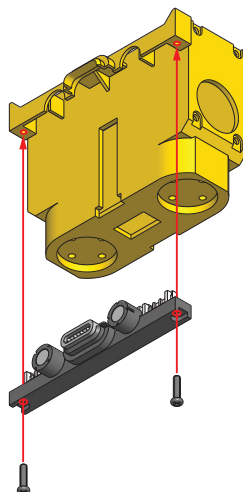
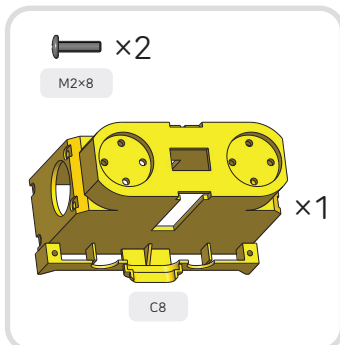

4

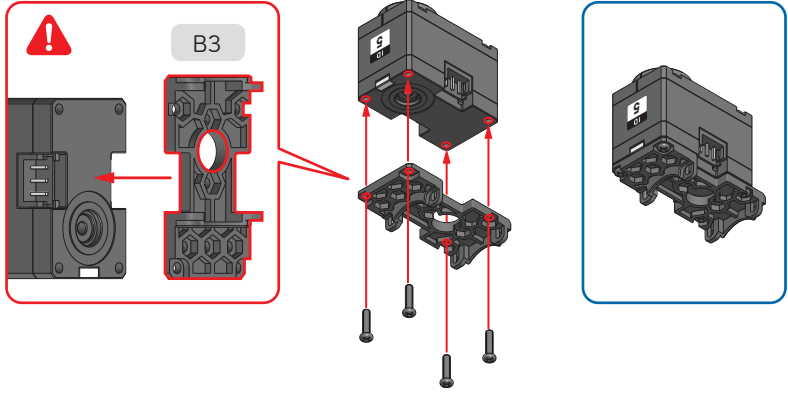
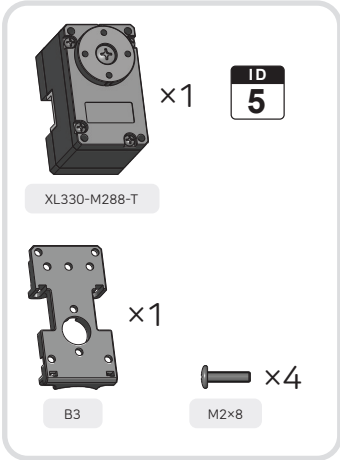

5

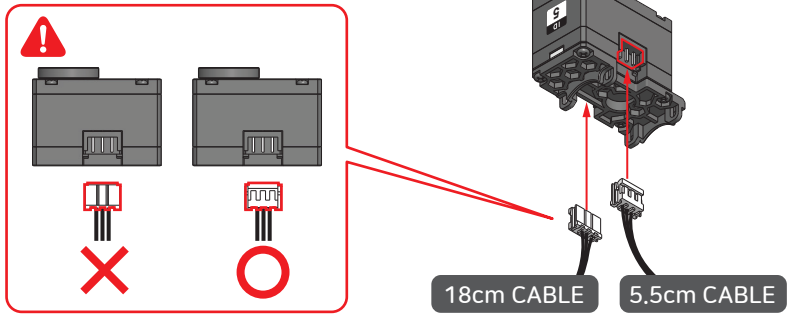
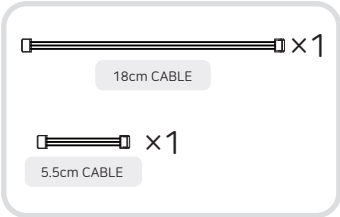

6

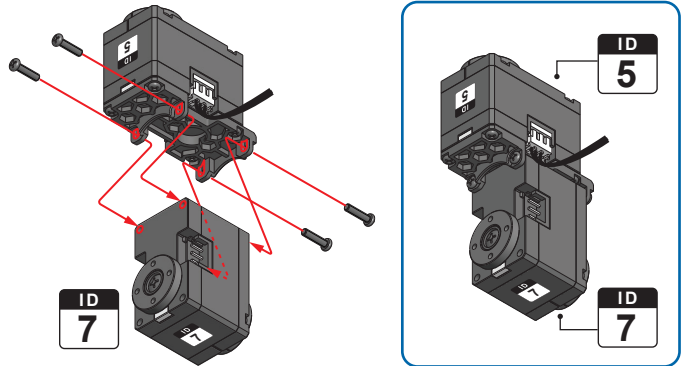
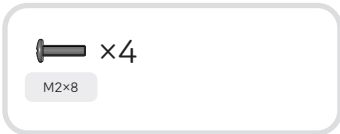

7

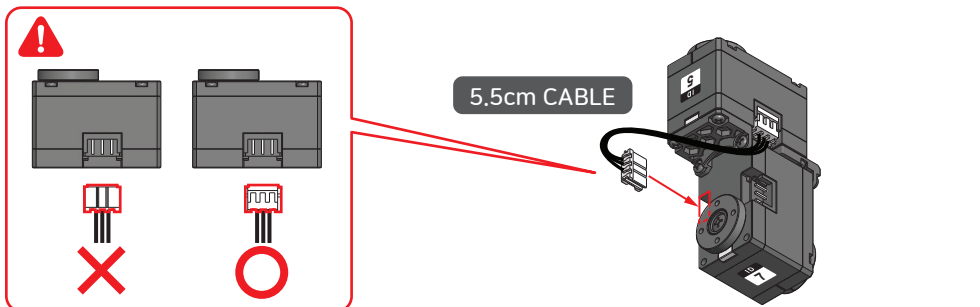

8

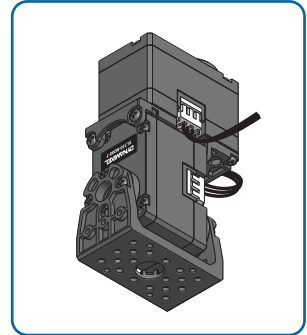
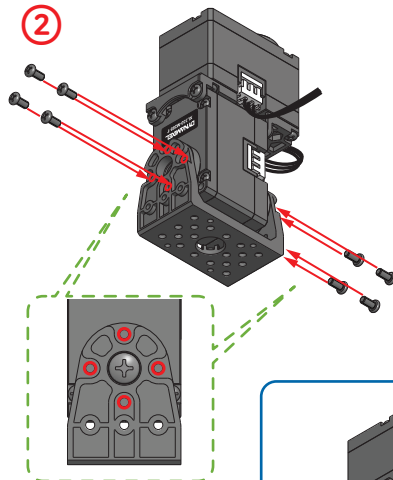
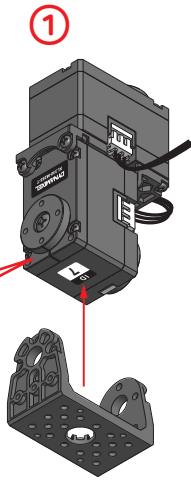
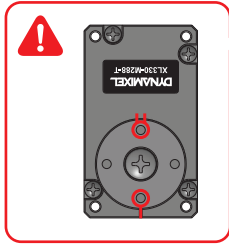
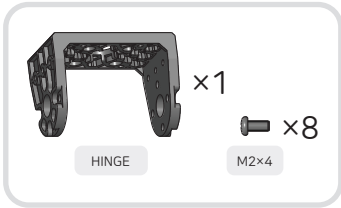

9

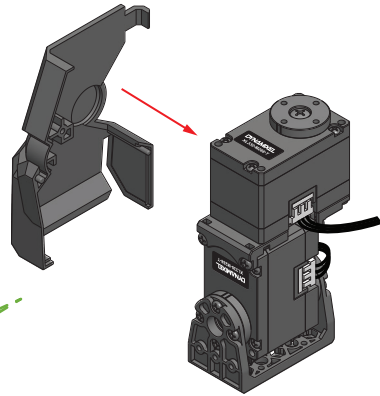
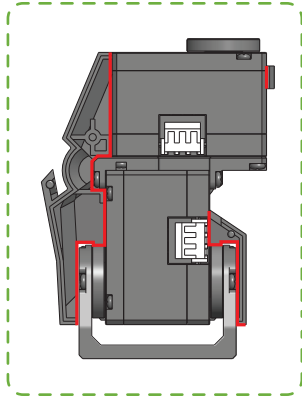
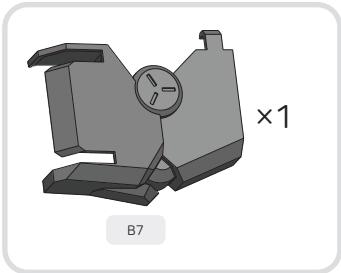

10

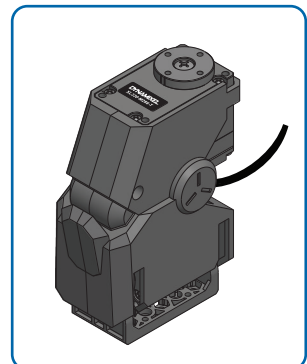
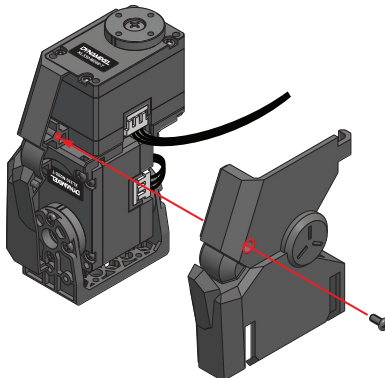
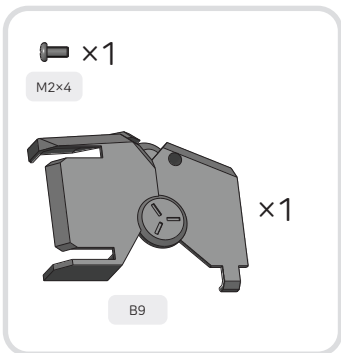

11

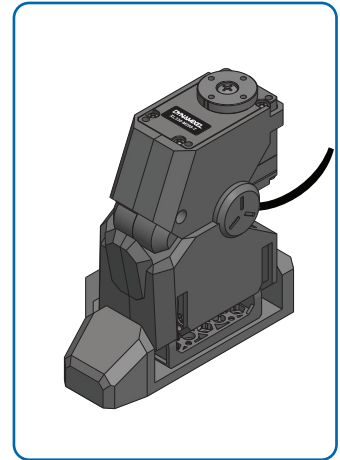
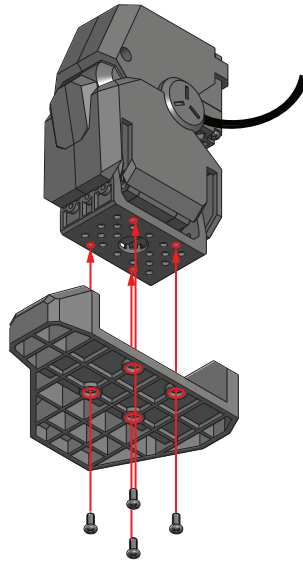
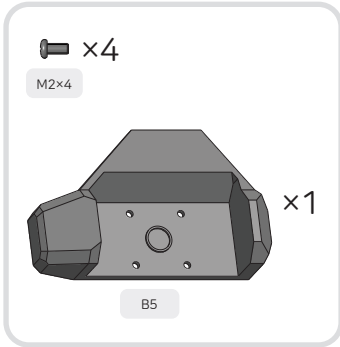

12

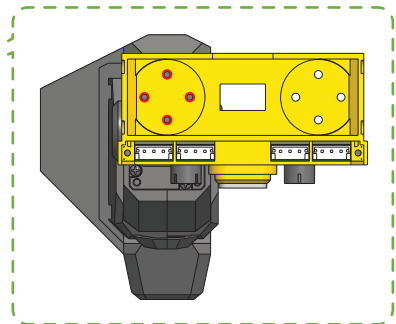
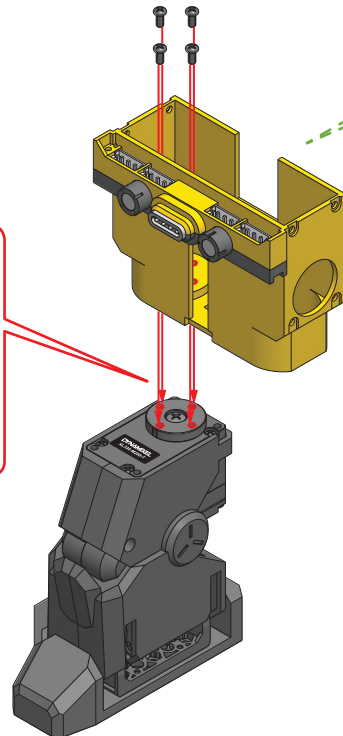
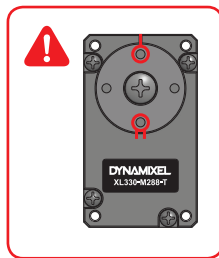
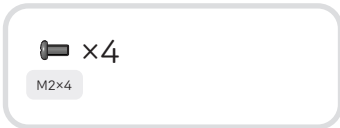

13

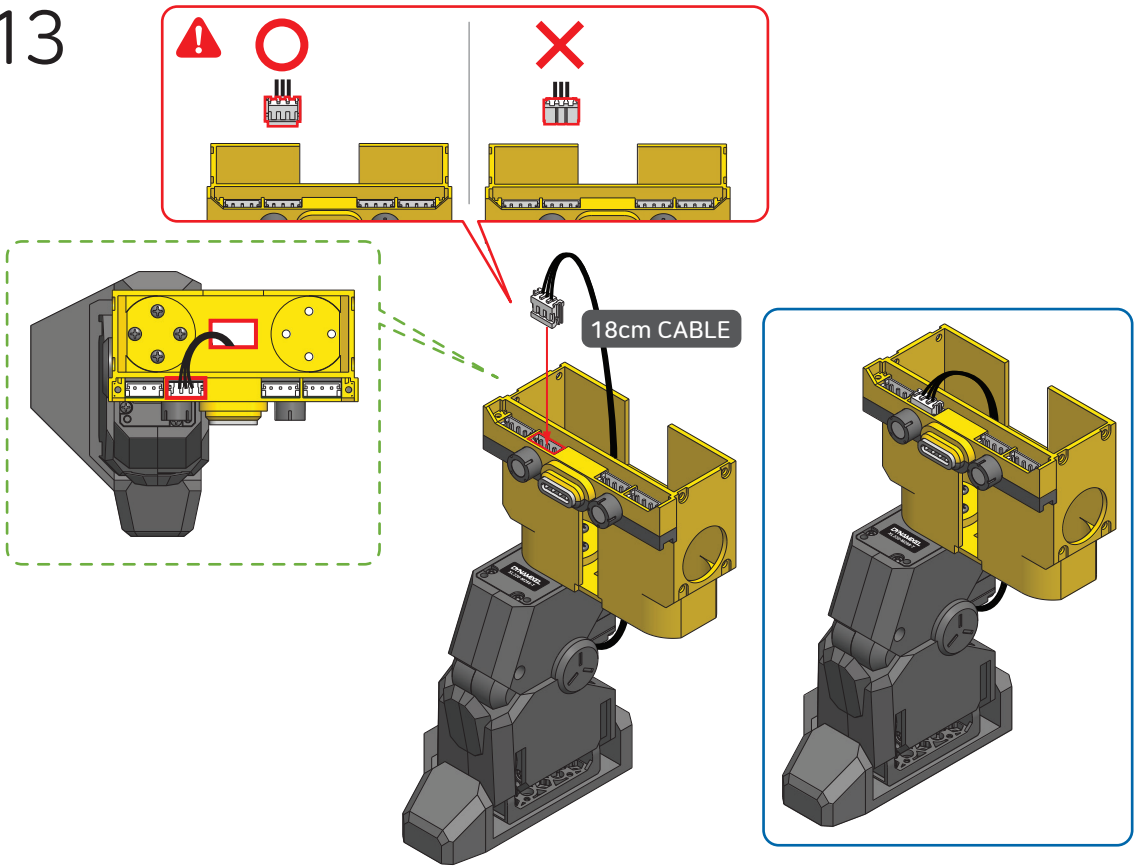

14

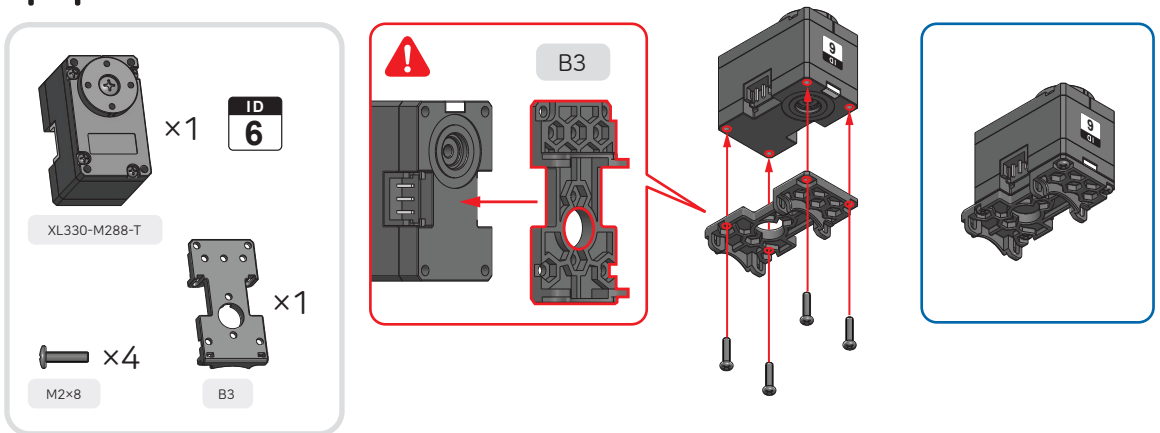

15

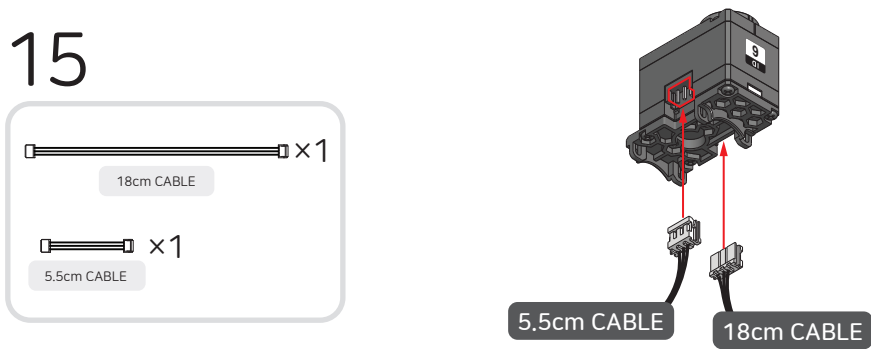

16

M2x8 x4

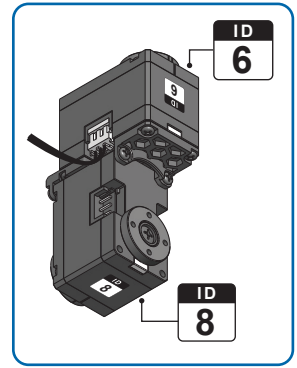
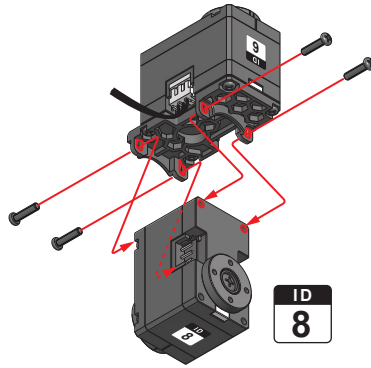

17

5.5cm CABLE

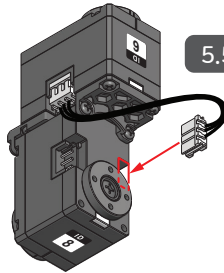

18

M2x4 x8

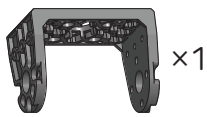

HINGE

①

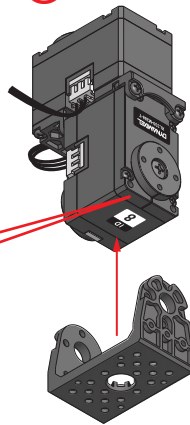

②

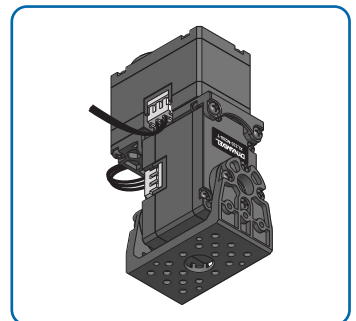
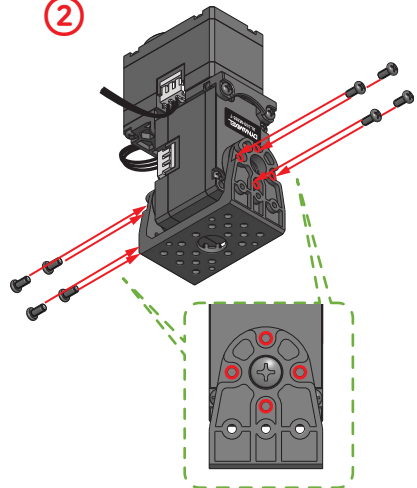

19

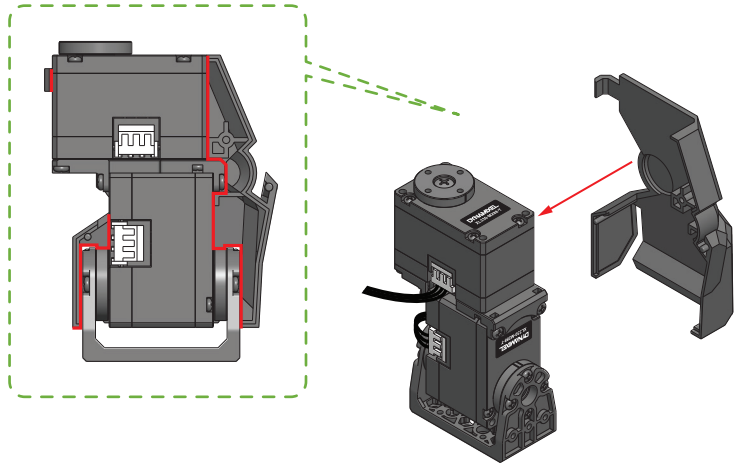
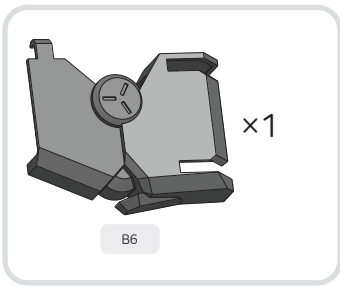

20

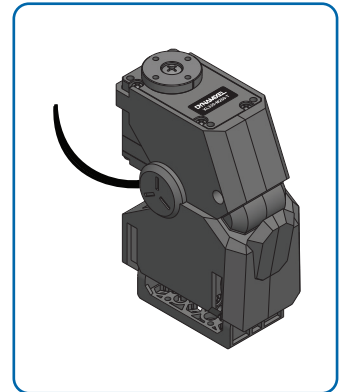
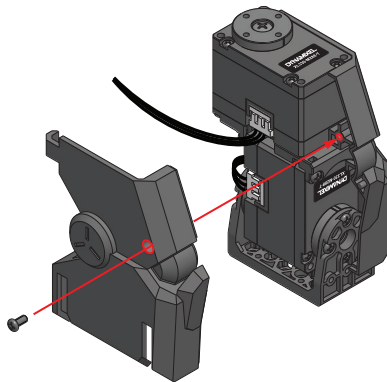
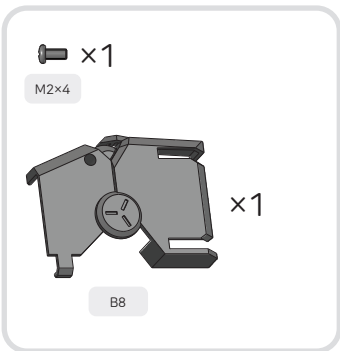

21

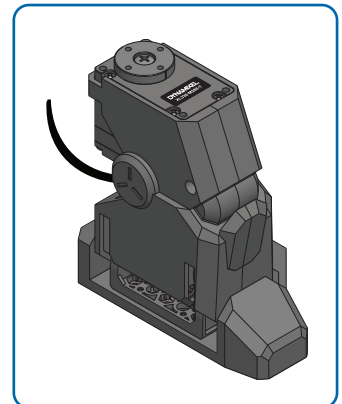
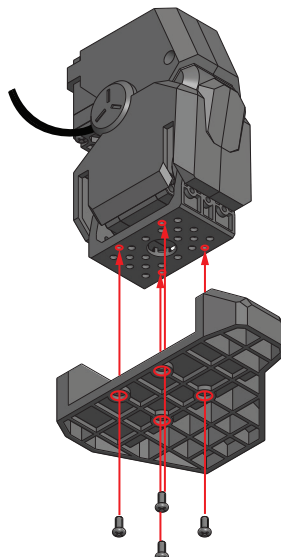
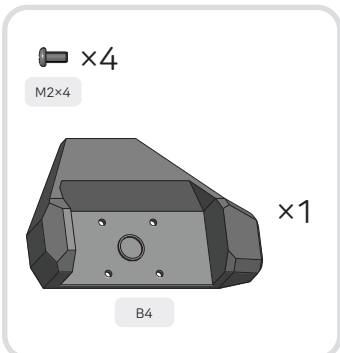

22

×4
M2×4

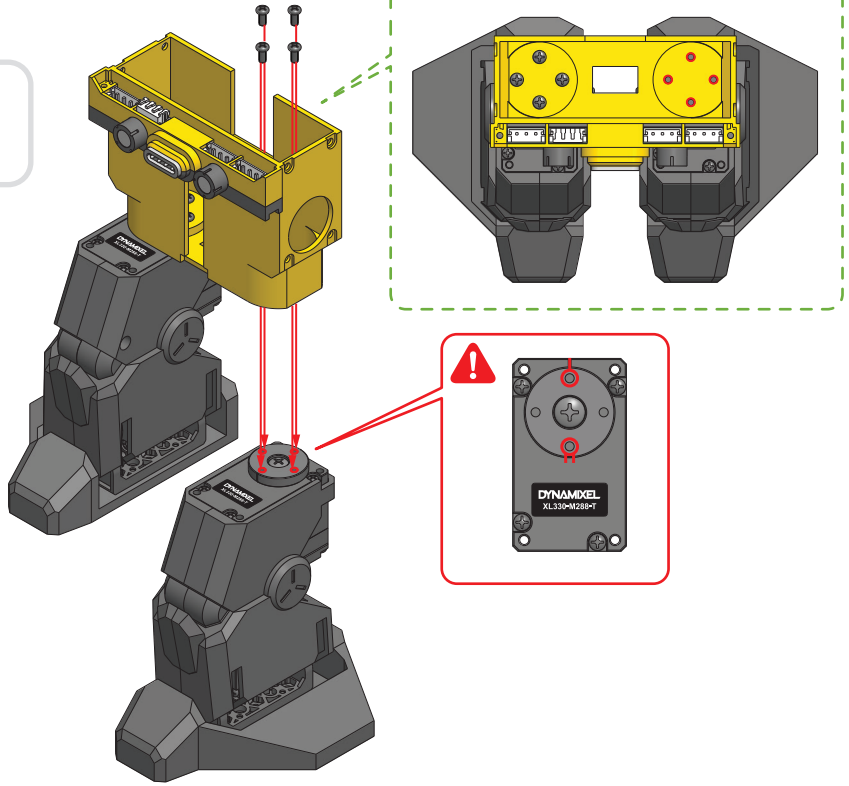

23

18cm CABLE

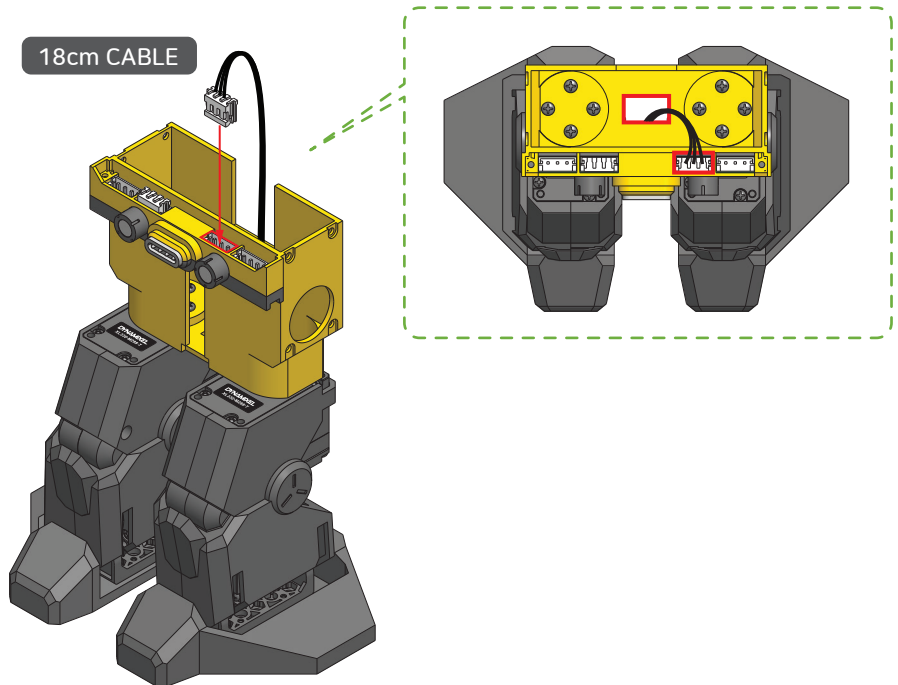

24

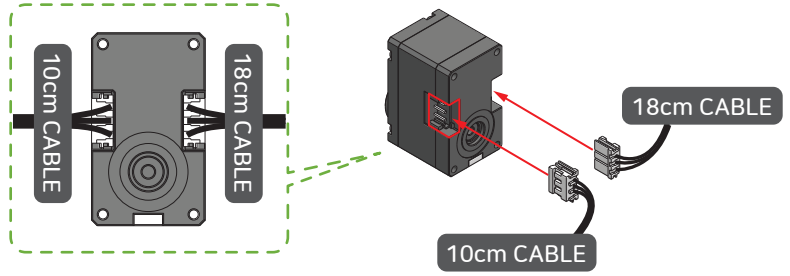
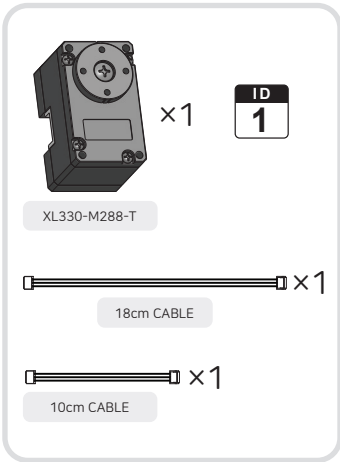

25

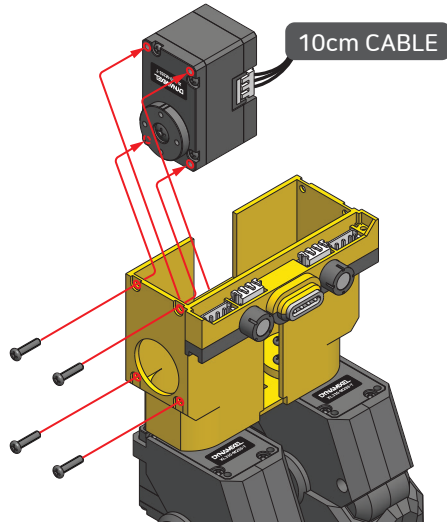
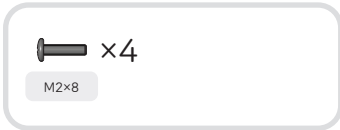

26

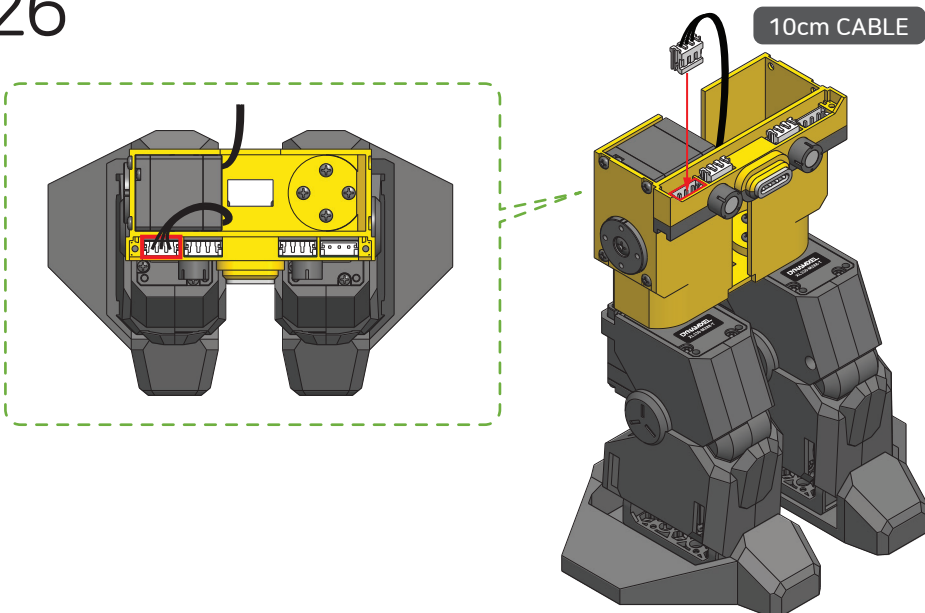

27

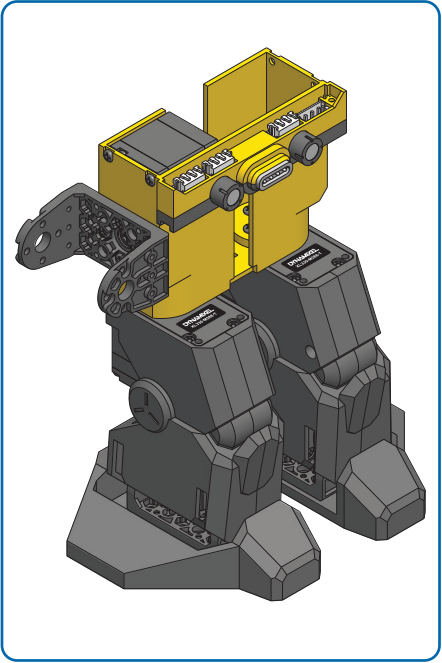
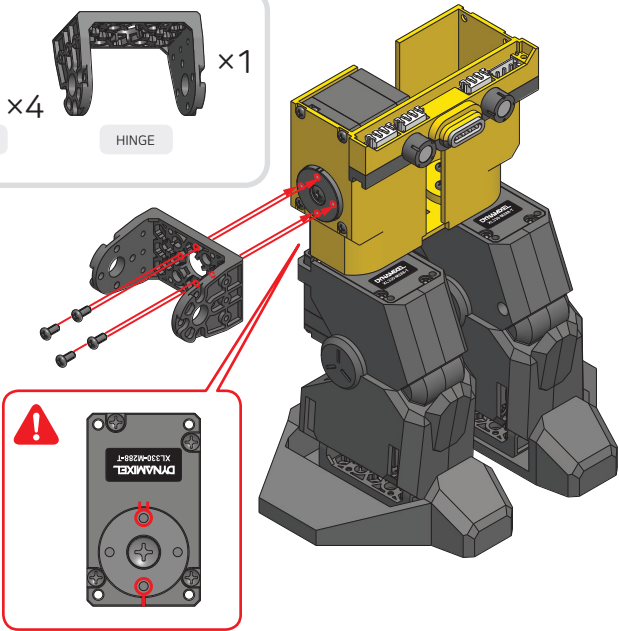
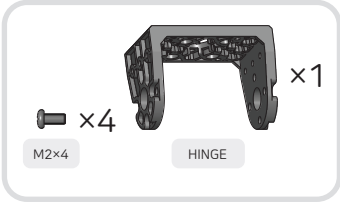

28

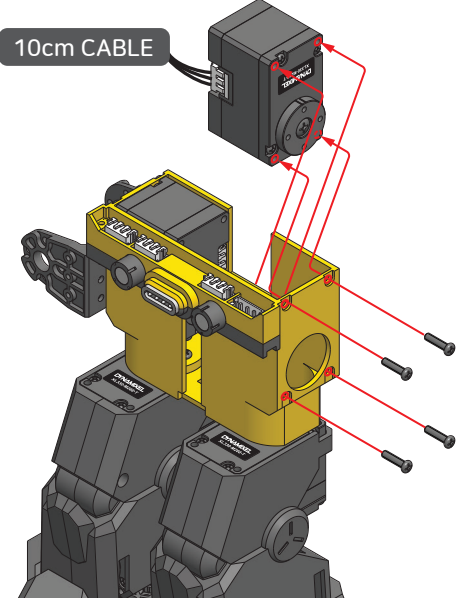
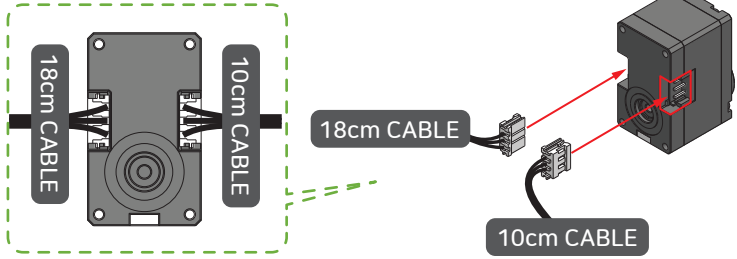
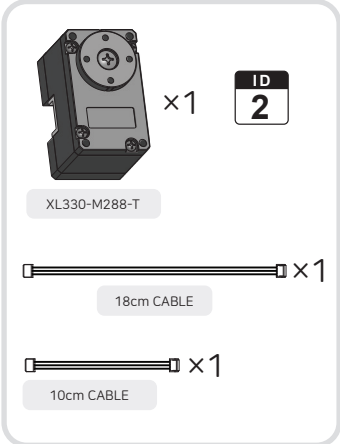

29

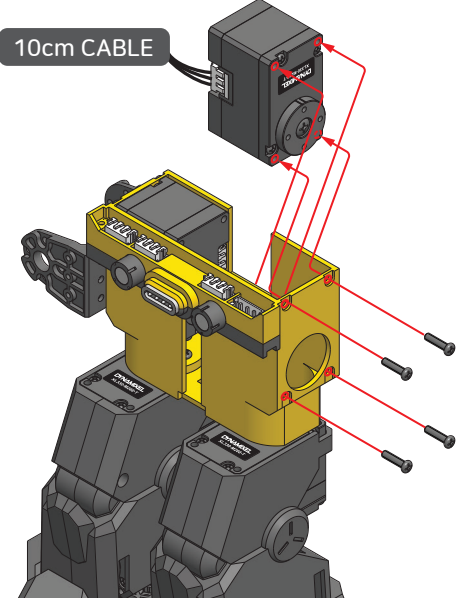
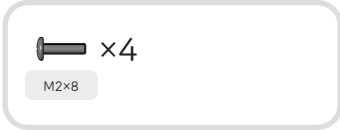

30

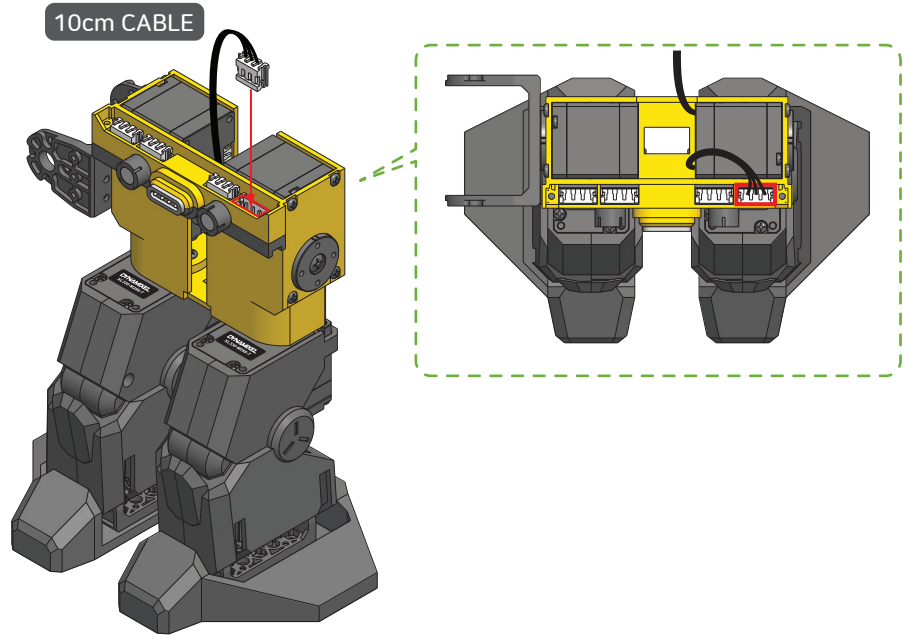

31

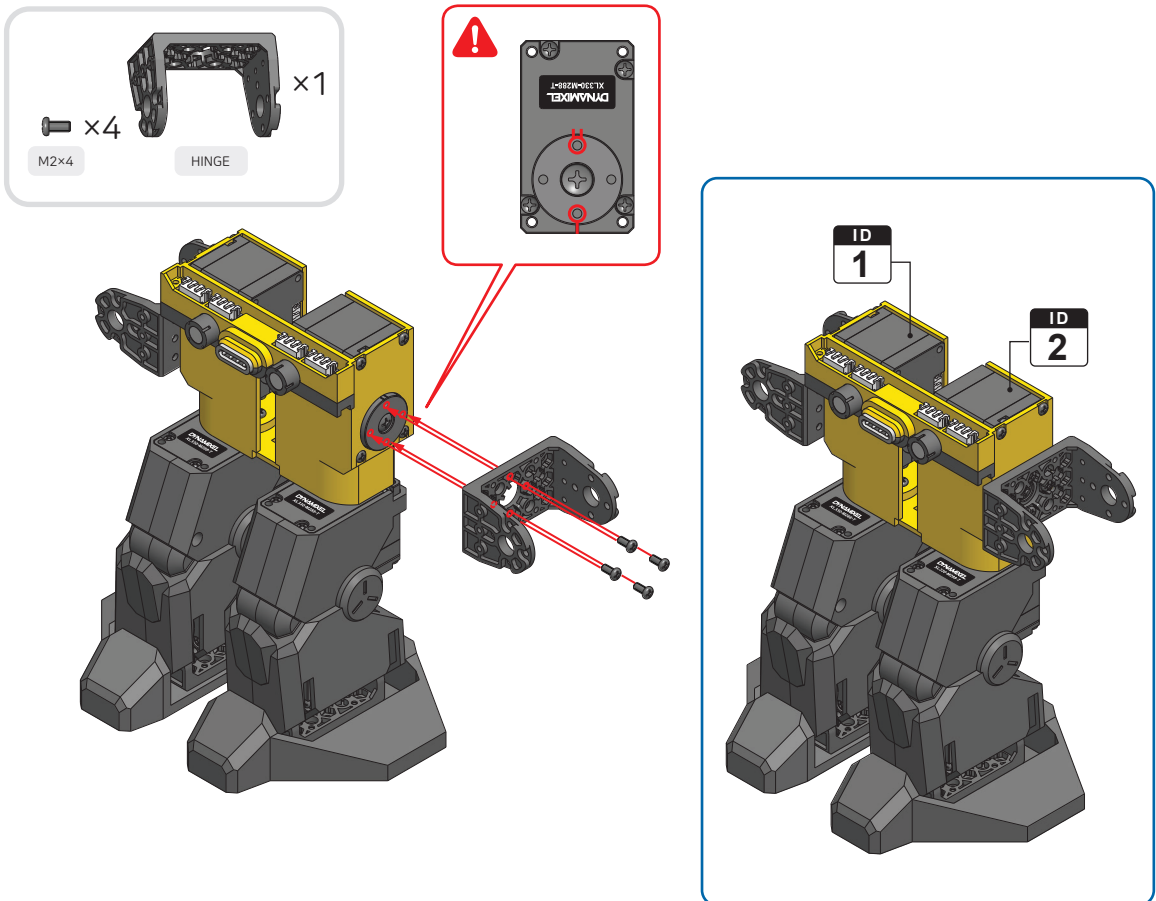

32

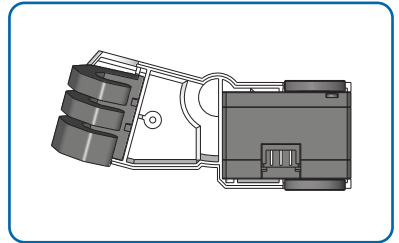
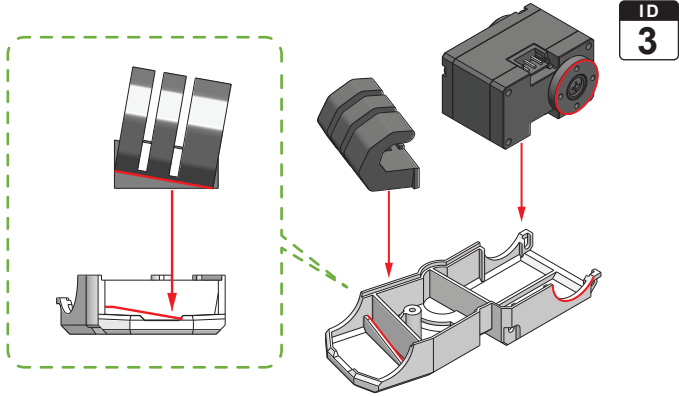
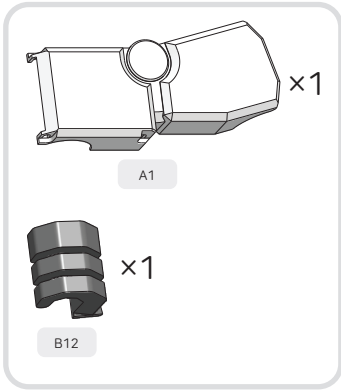

33

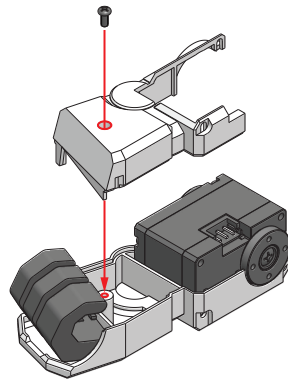
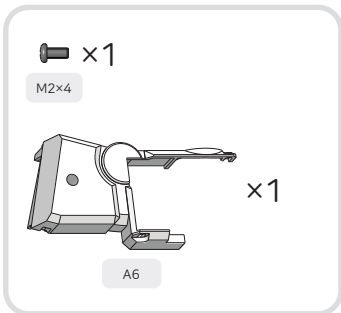

34

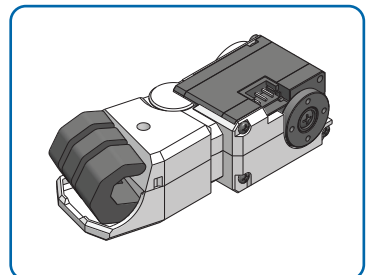
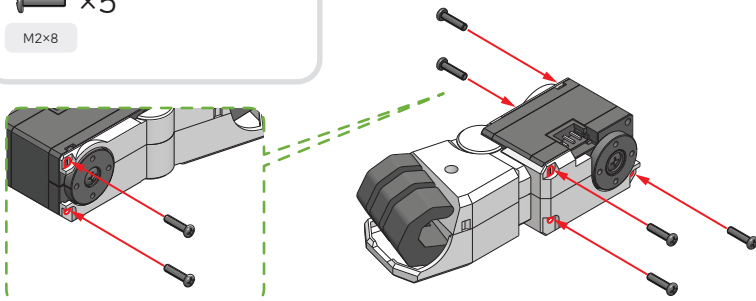
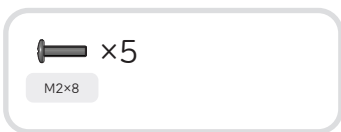

35

🔩 × 8
M2×4

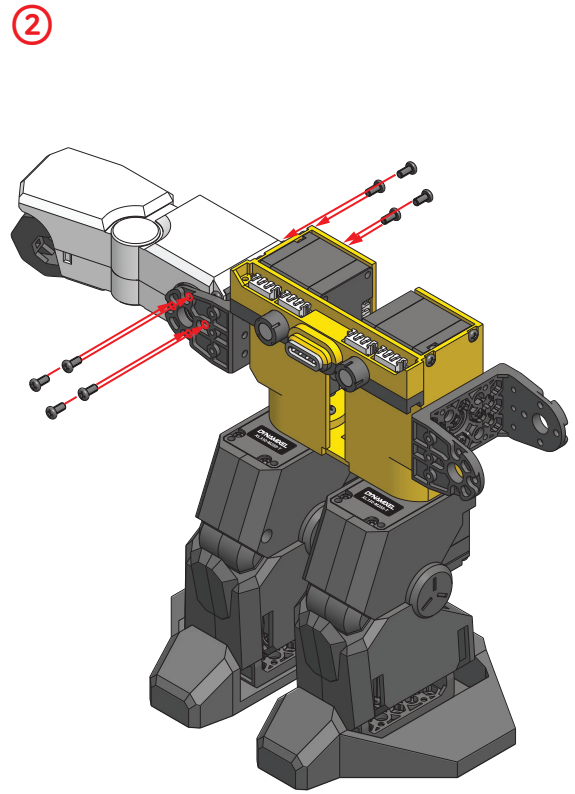
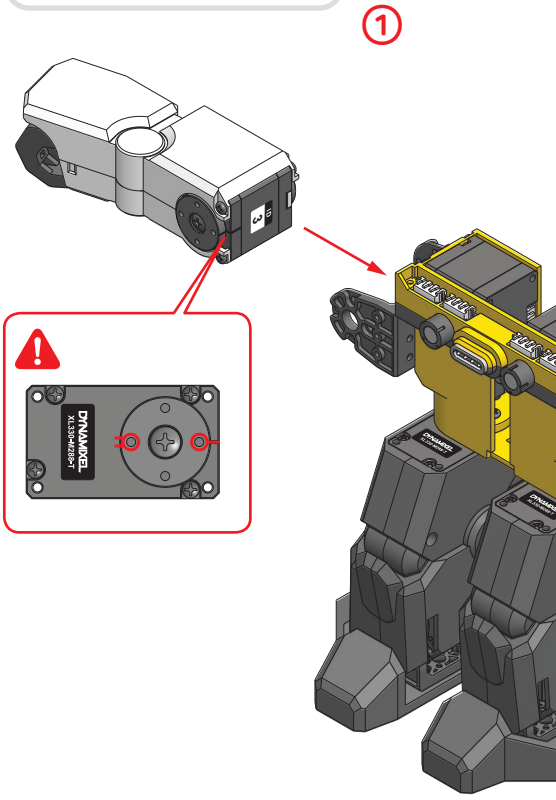

36

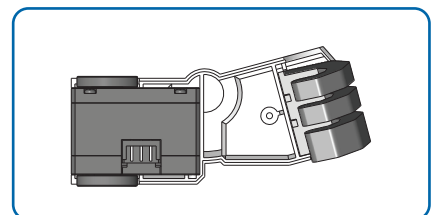
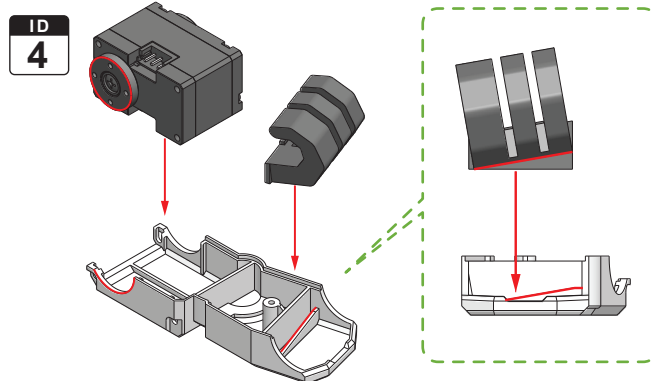
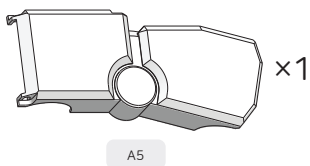

37

×1
M2×4

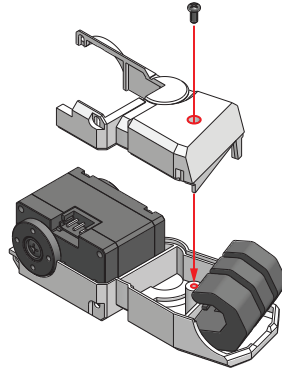
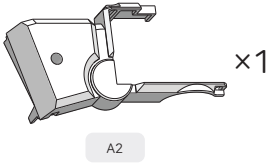

38

×5
M2×8

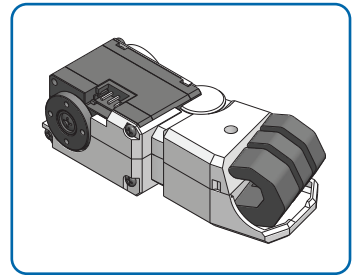
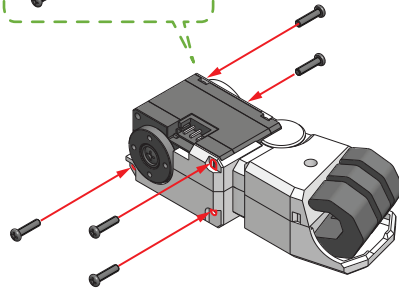
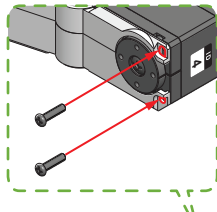

39

×8
M2×4

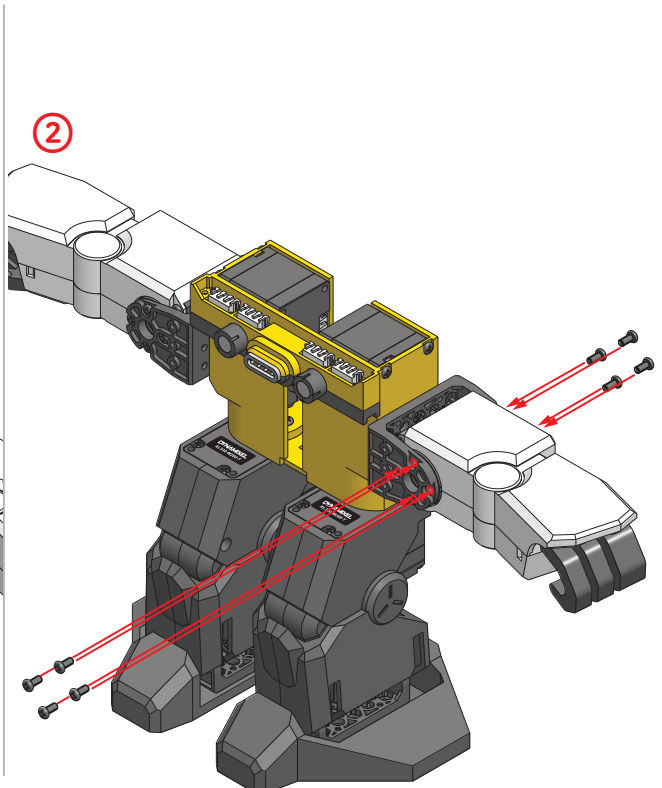
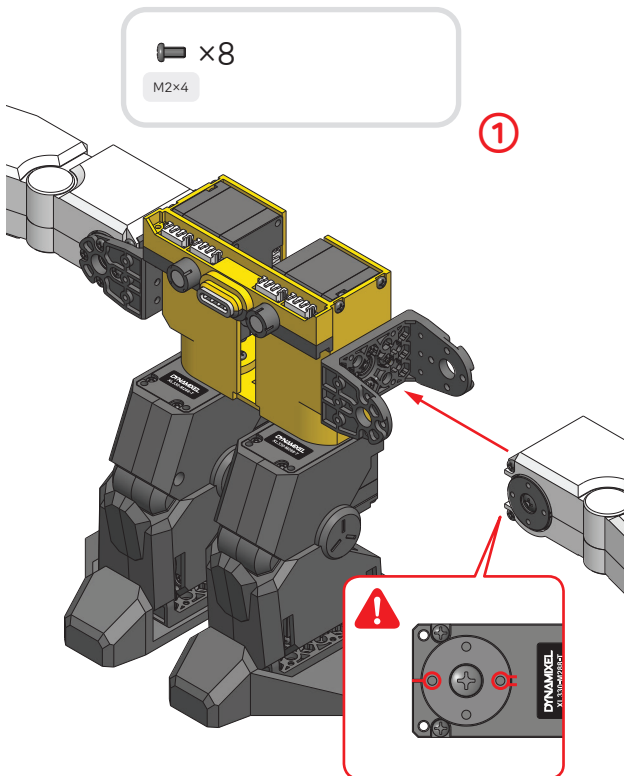

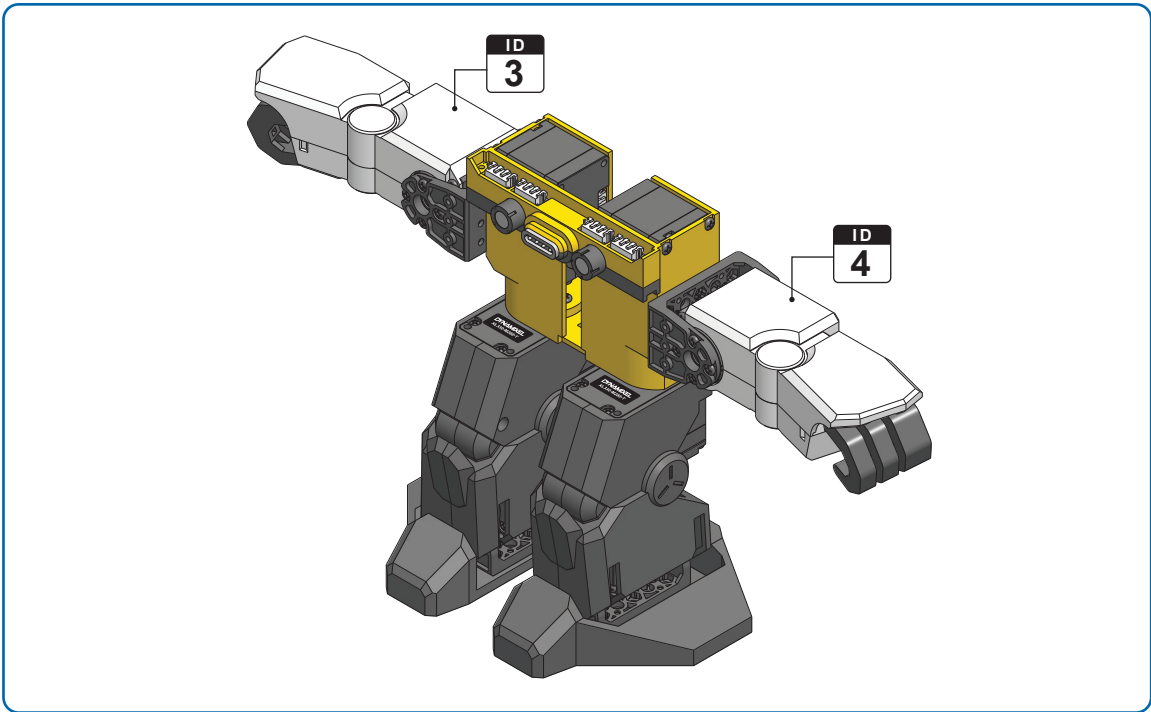

40

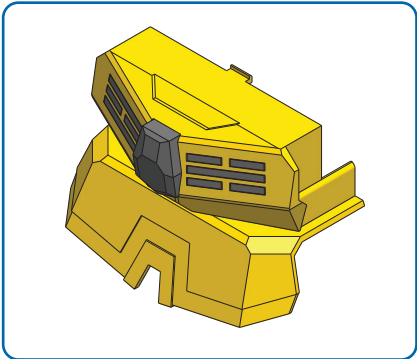
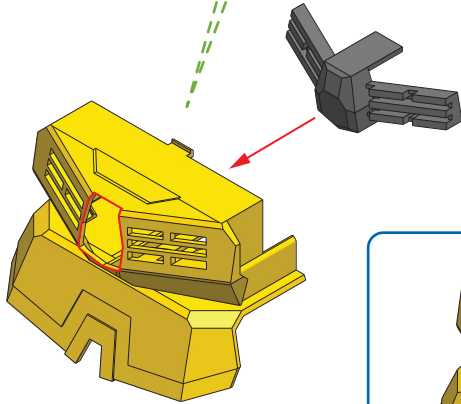
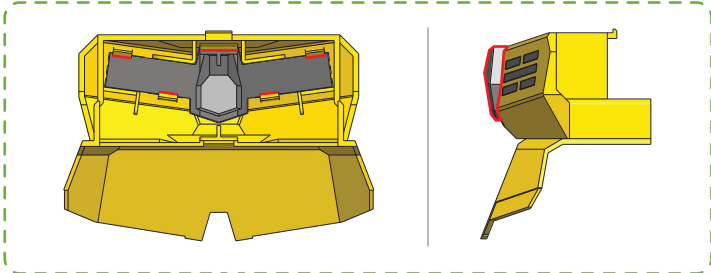
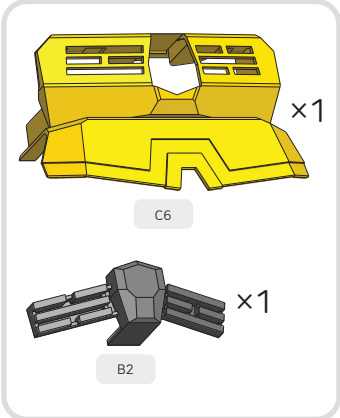

41

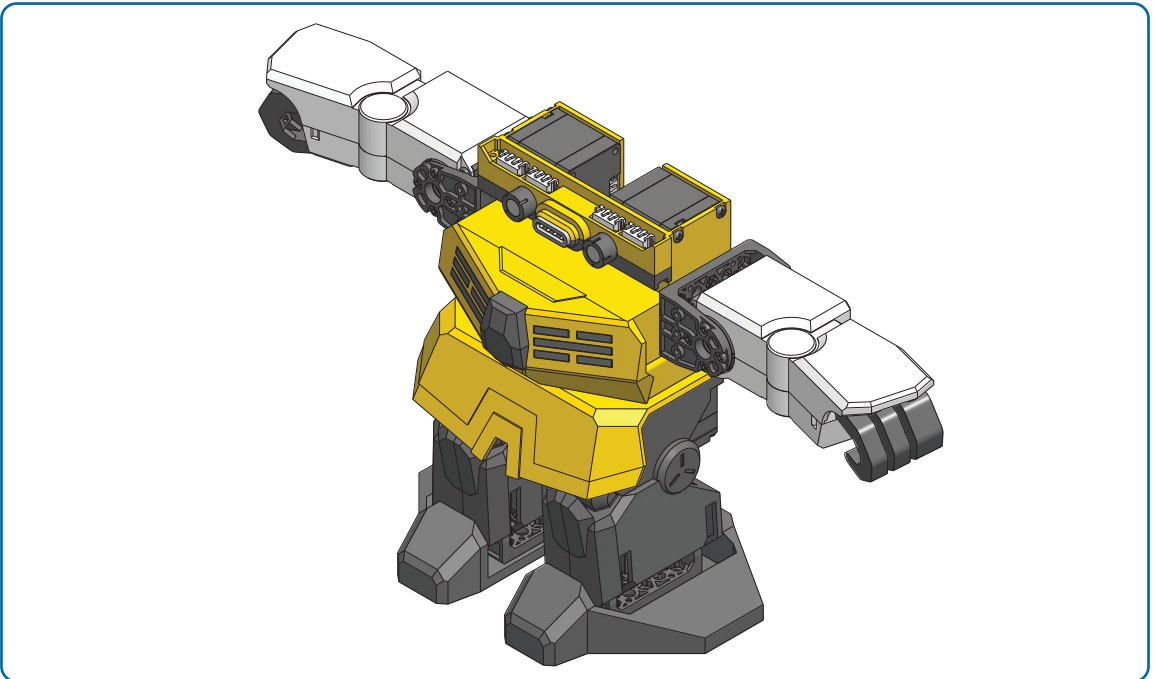
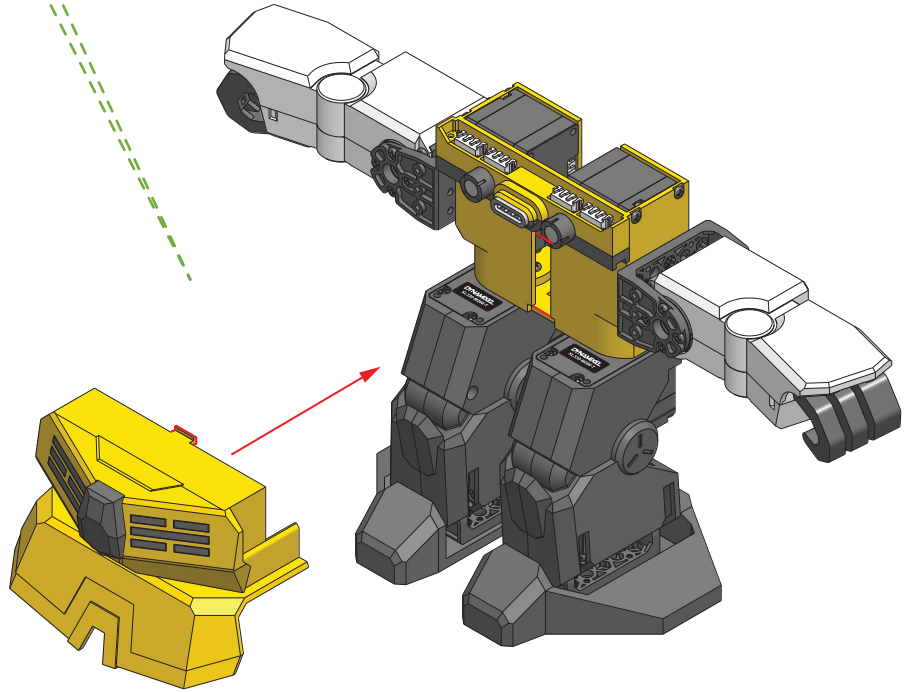
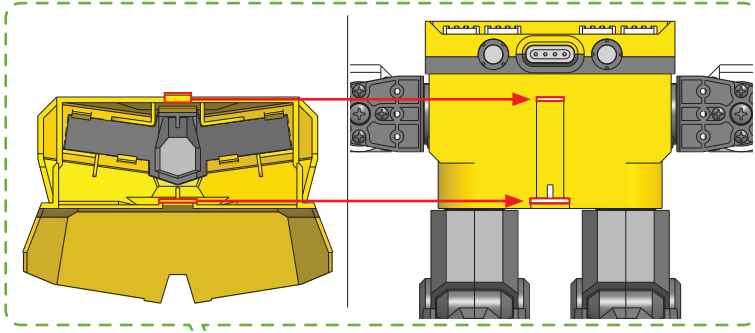

42

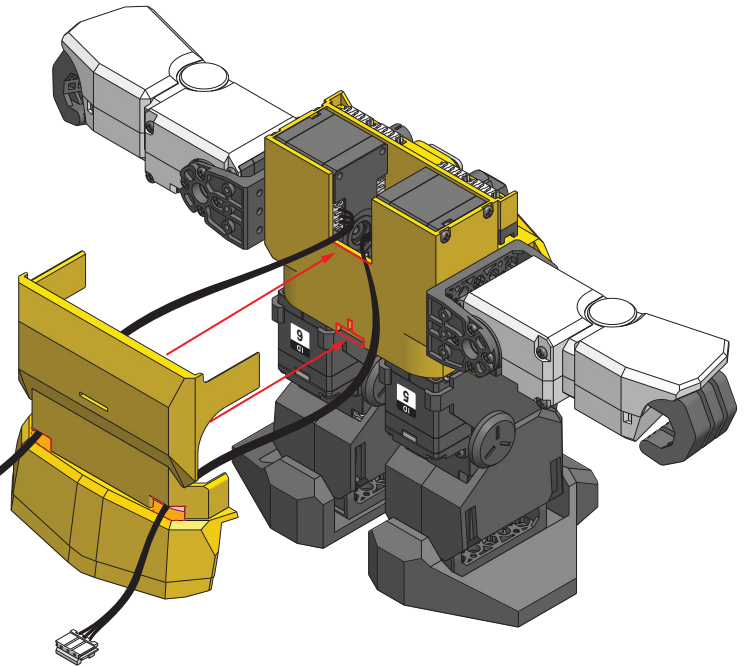
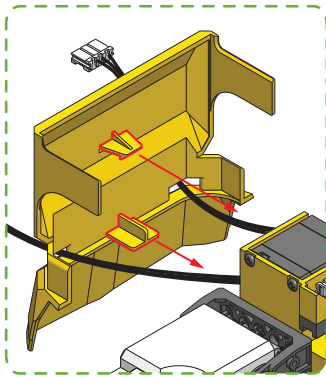
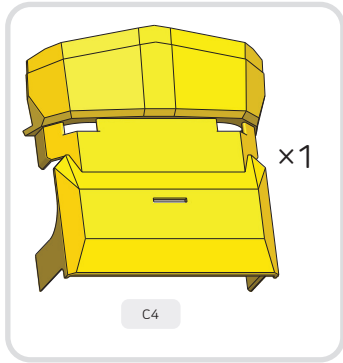

43

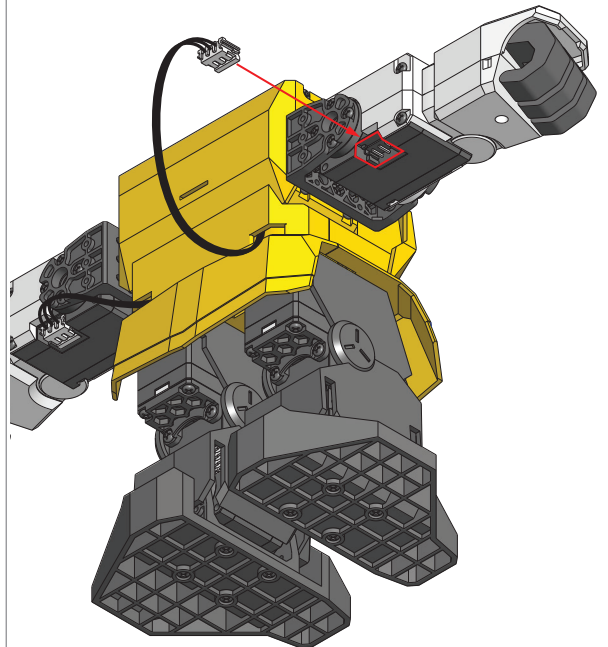
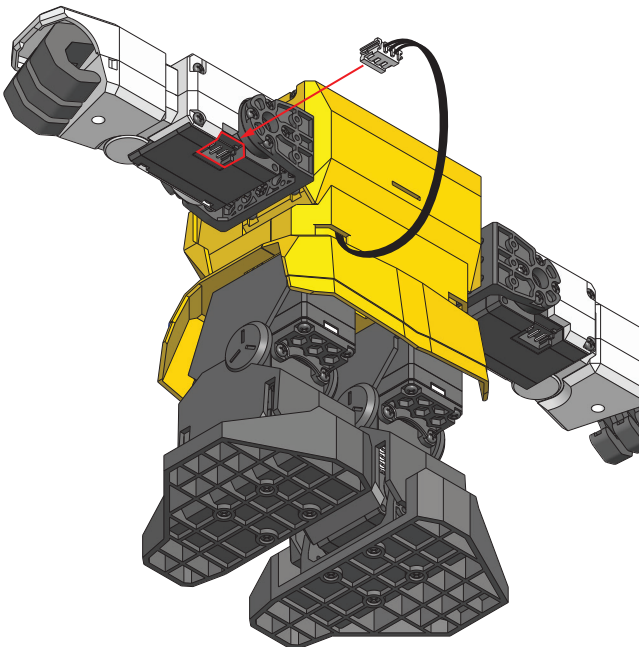

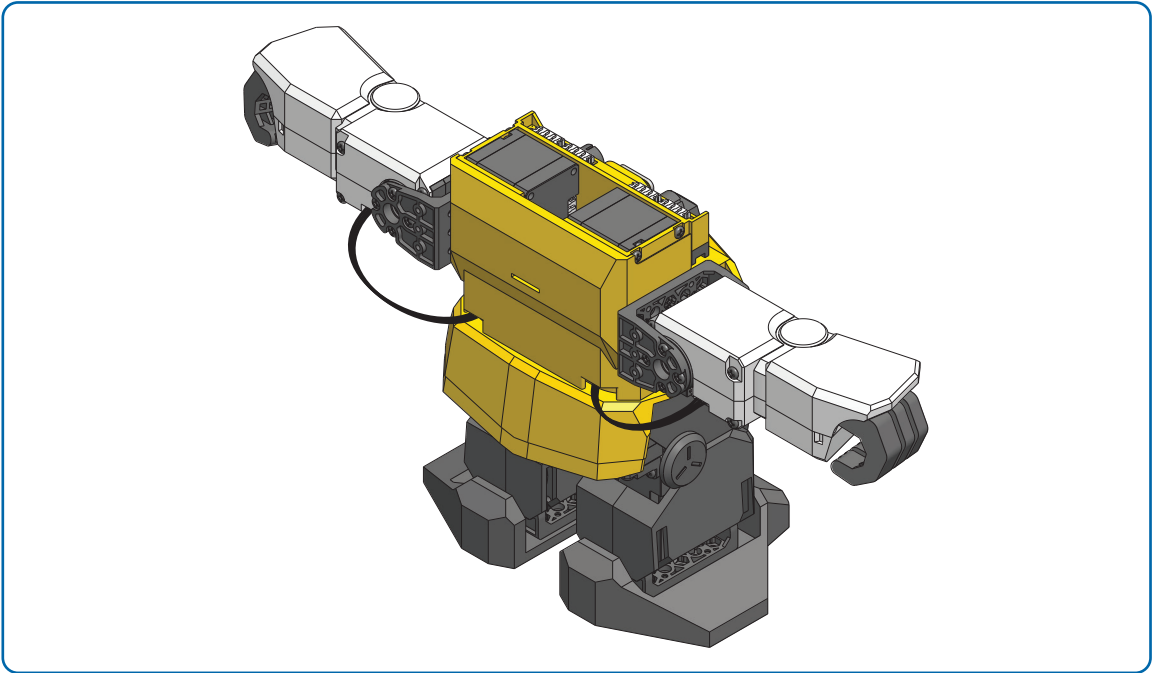

44

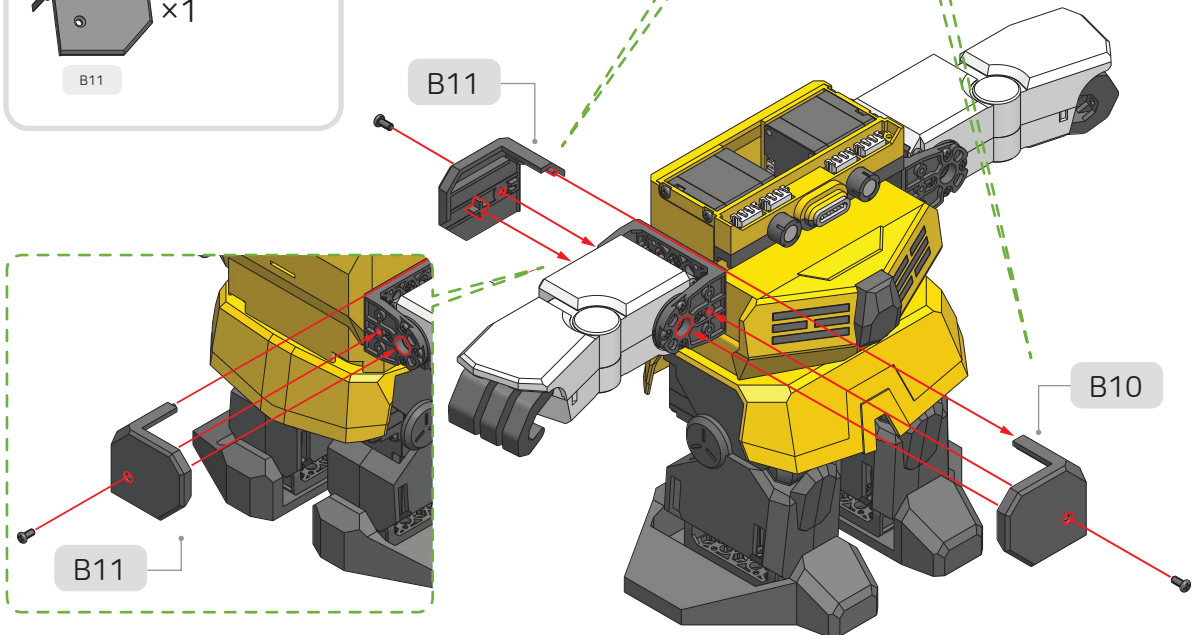
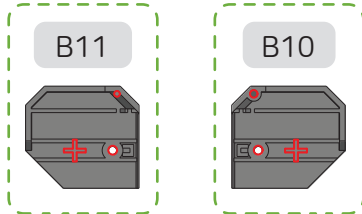
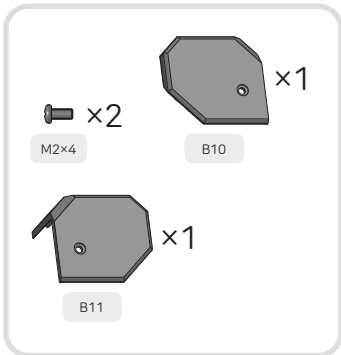

45

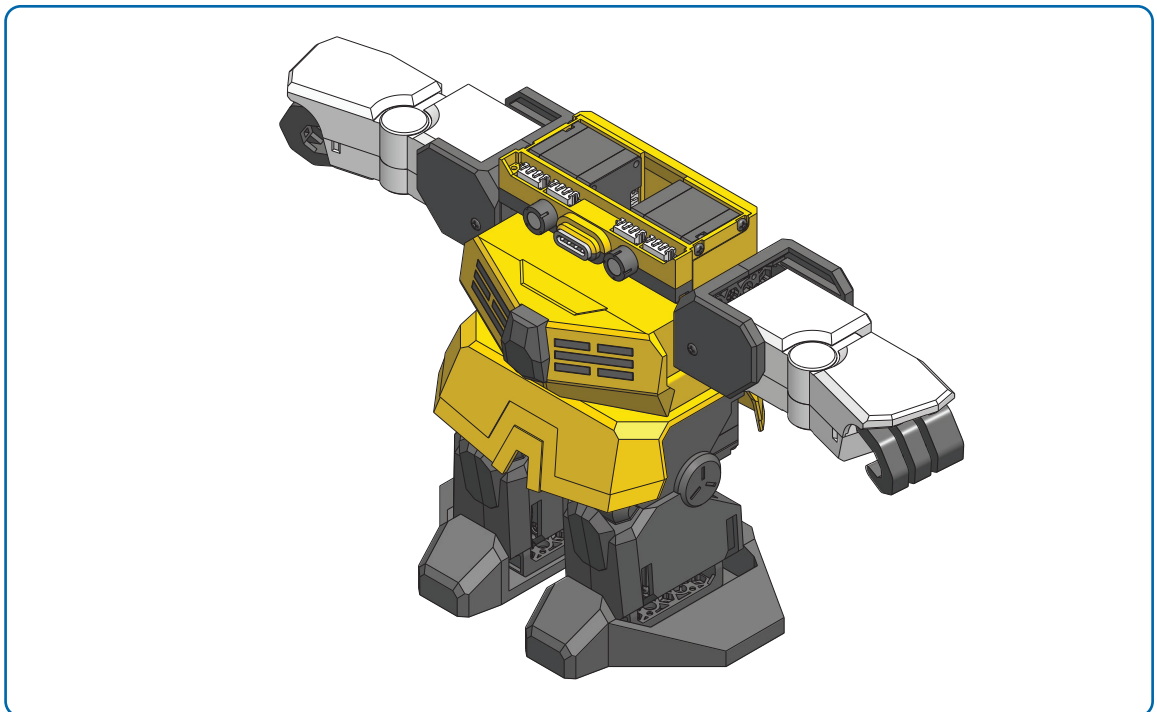
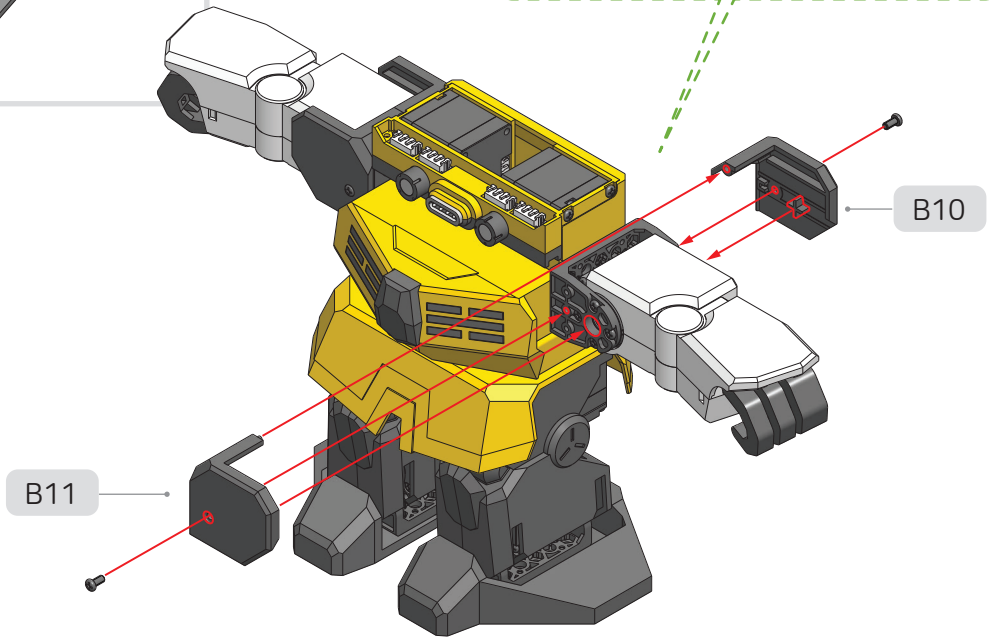
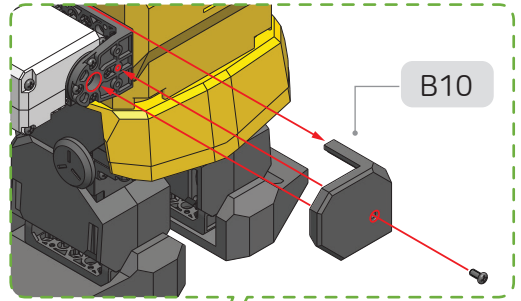
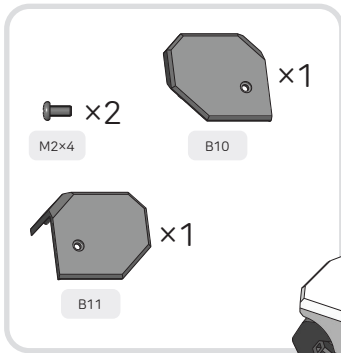

46

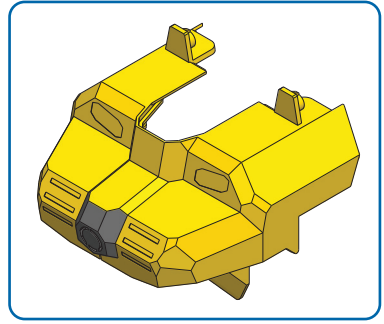
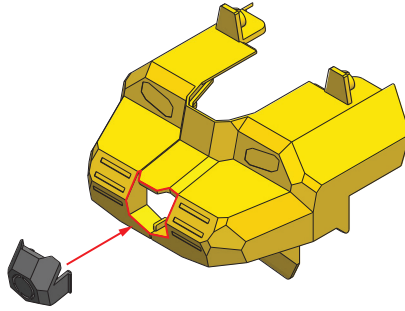
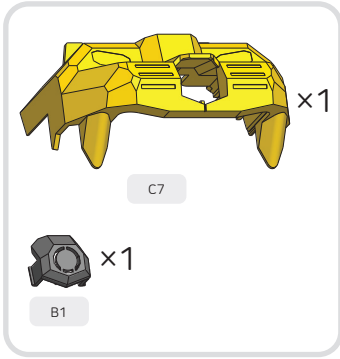

47

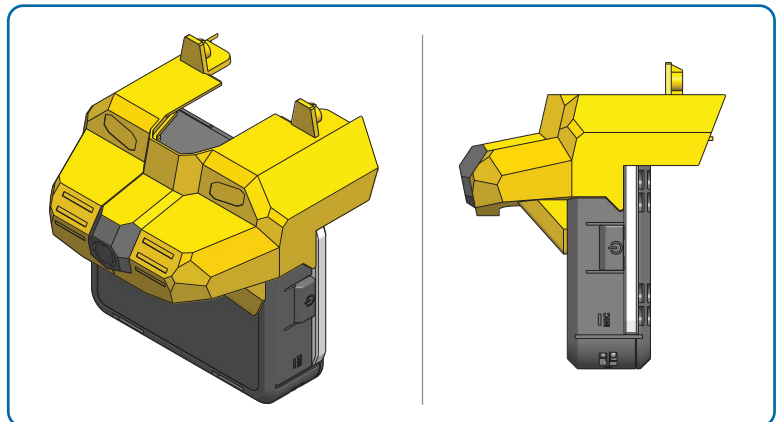
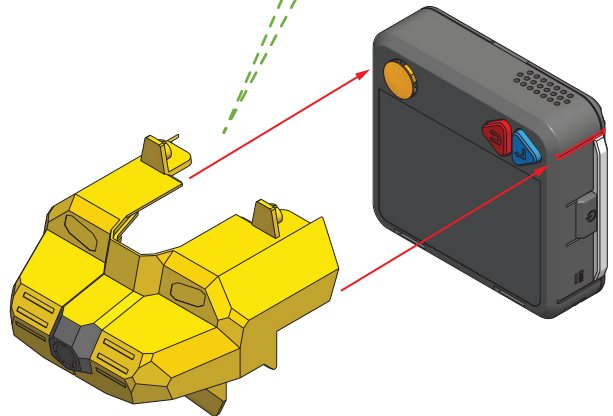
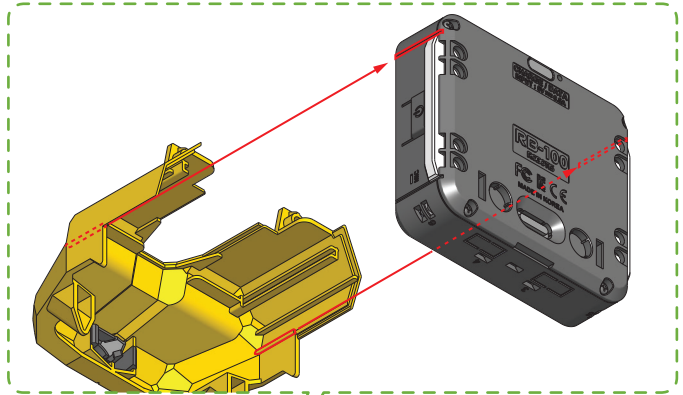

48

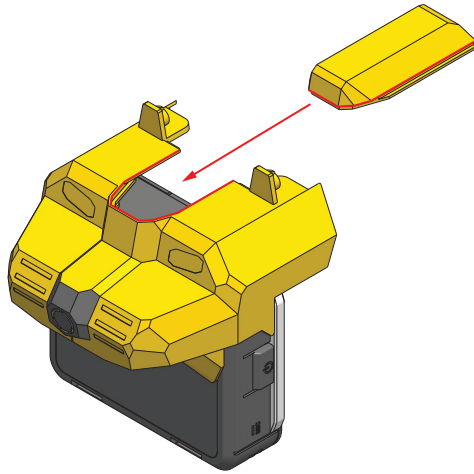
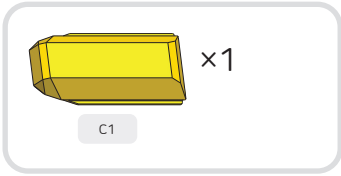

49

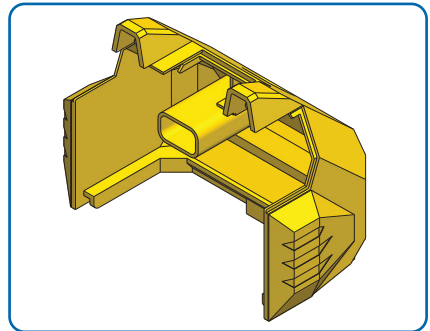
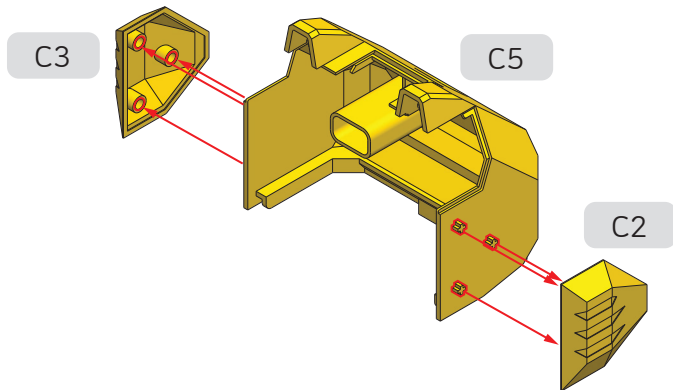
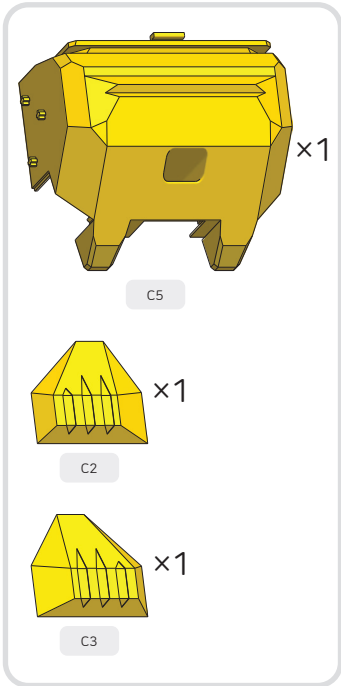

50

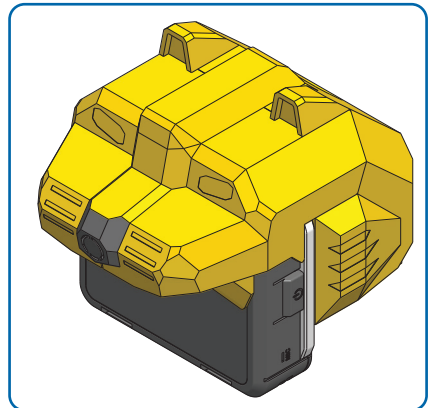
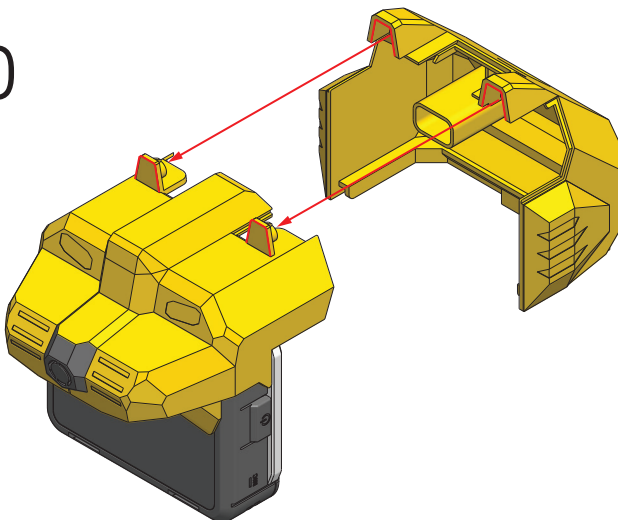

51

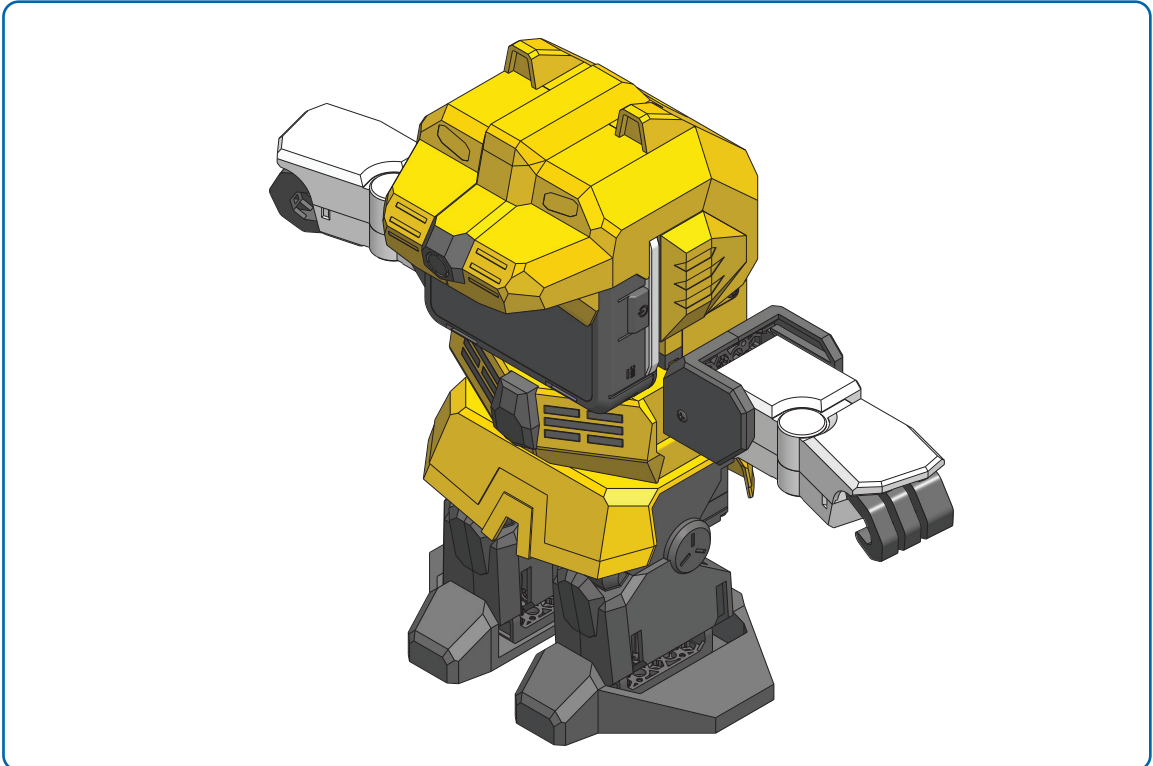
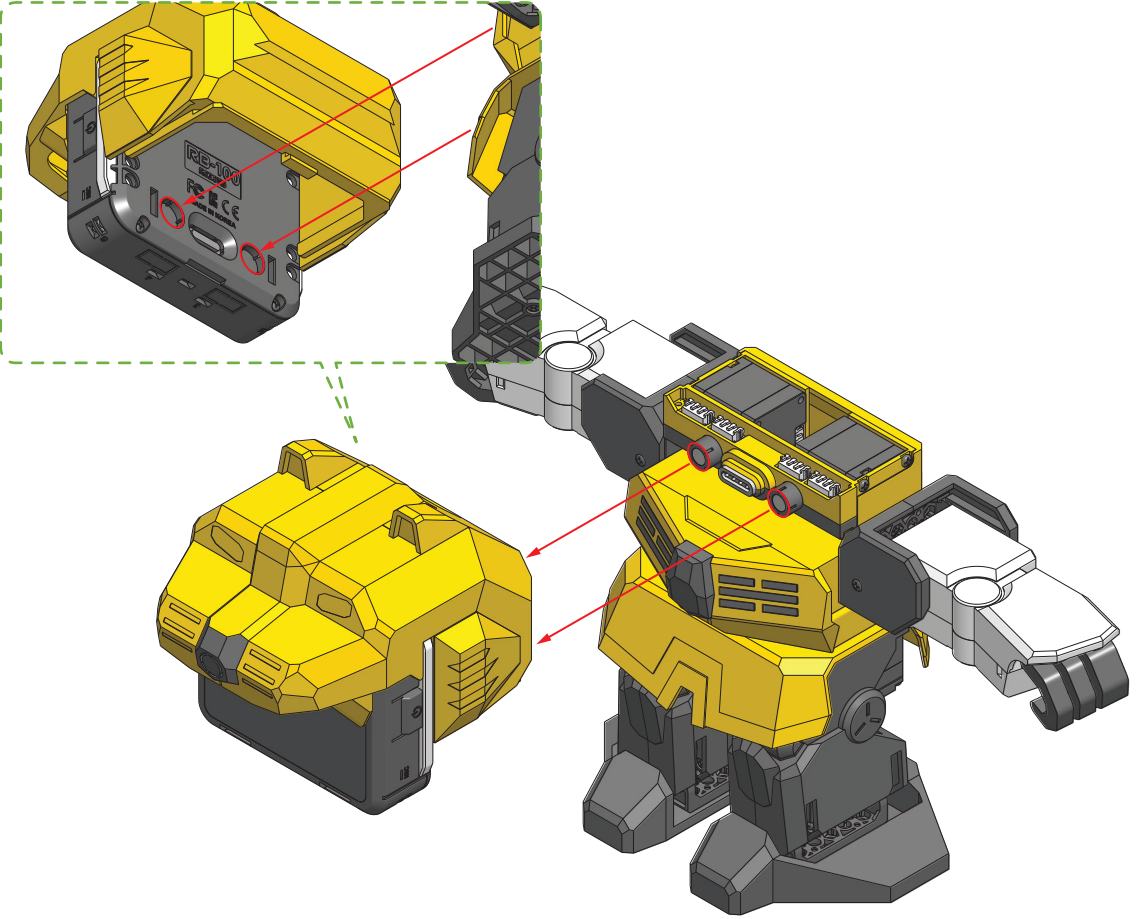

52

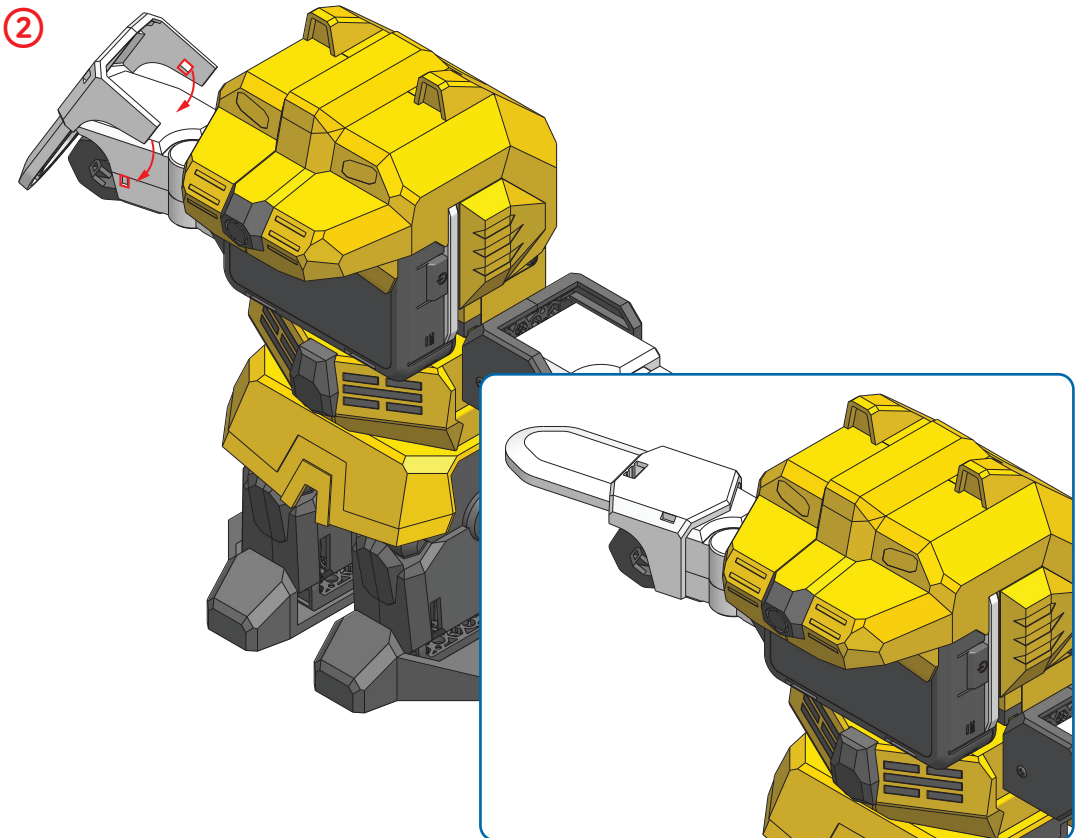
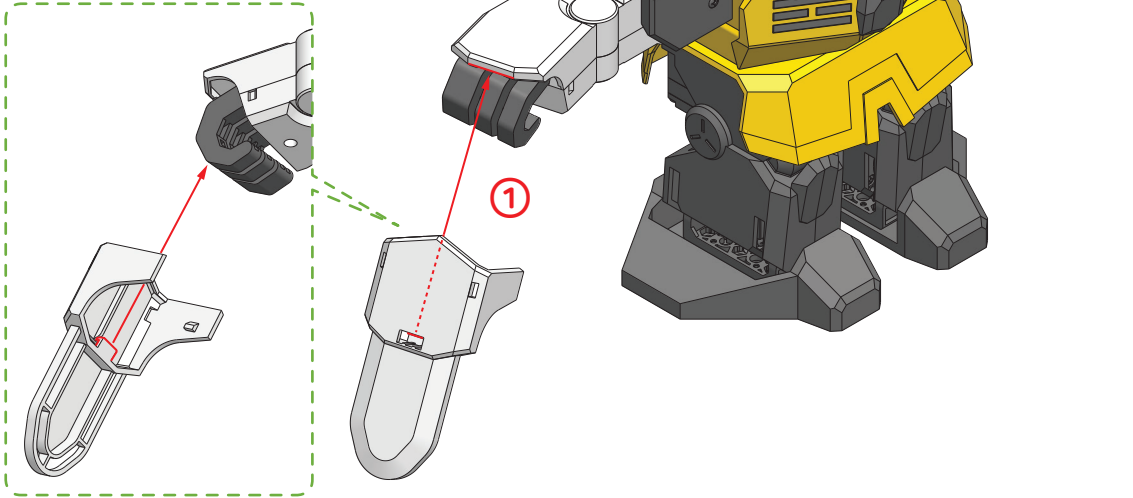
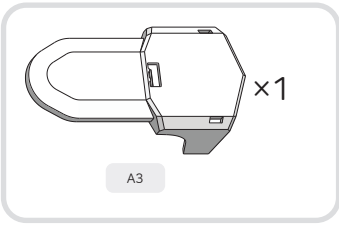

53

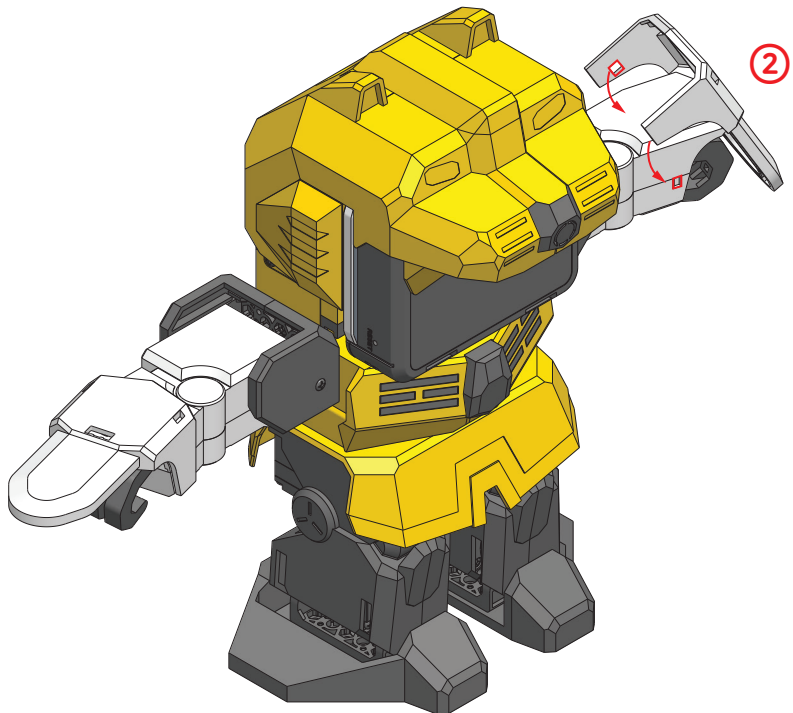
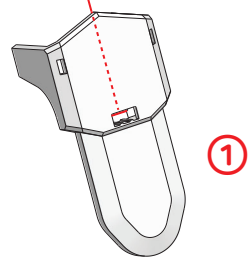
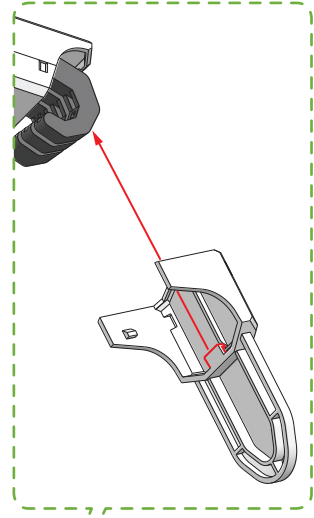
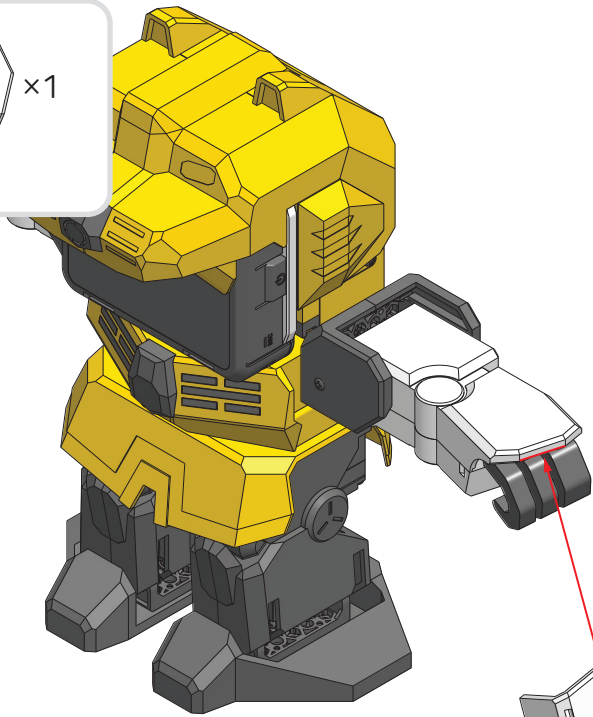
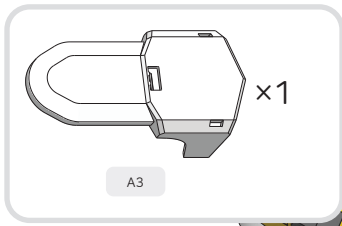

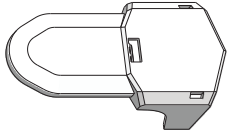

A3

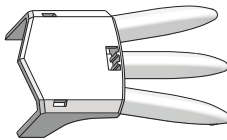
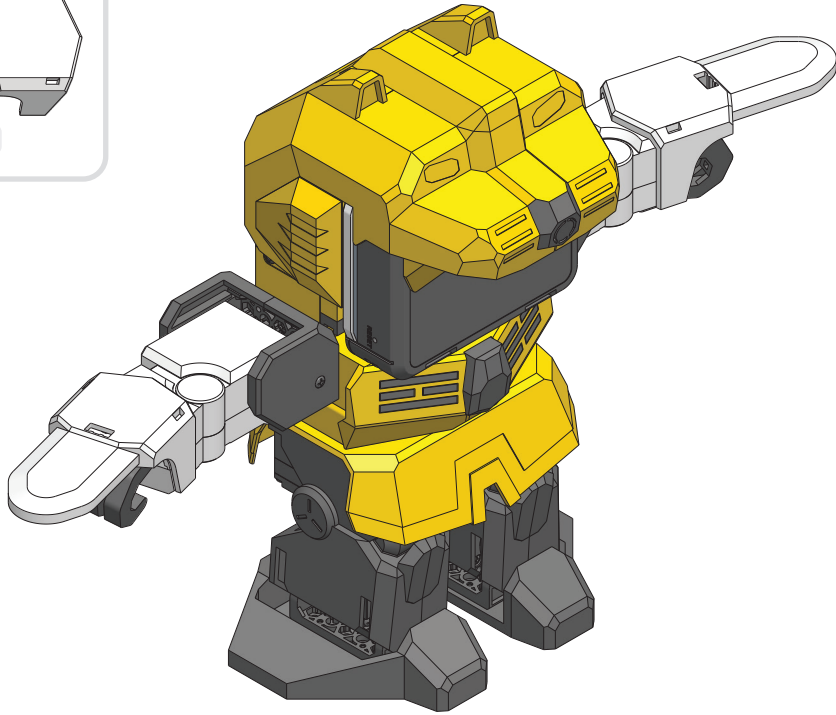

A4

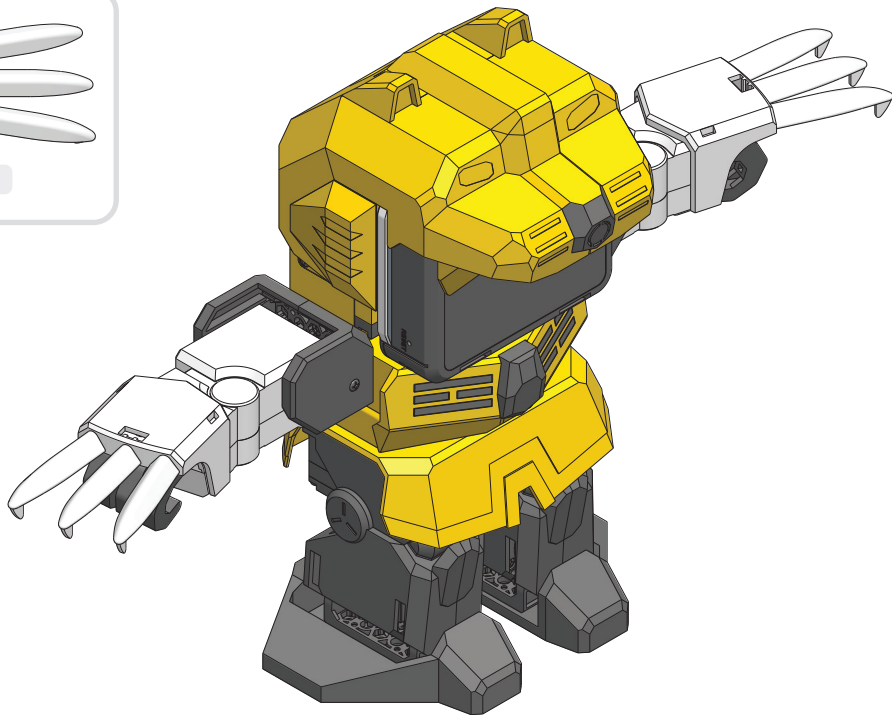



Decorate with stickers

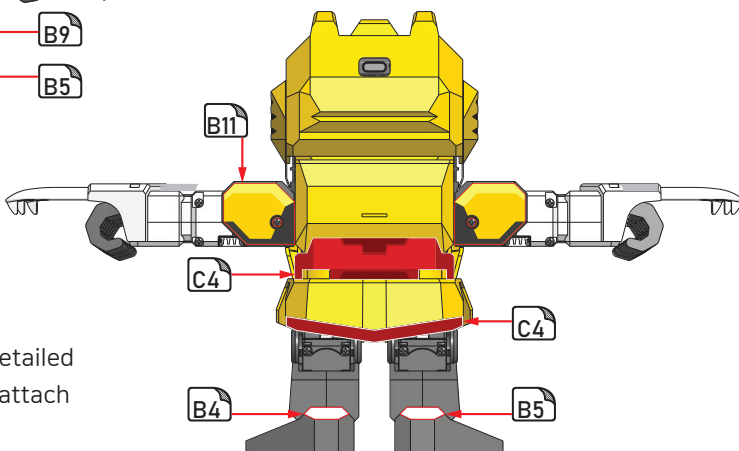
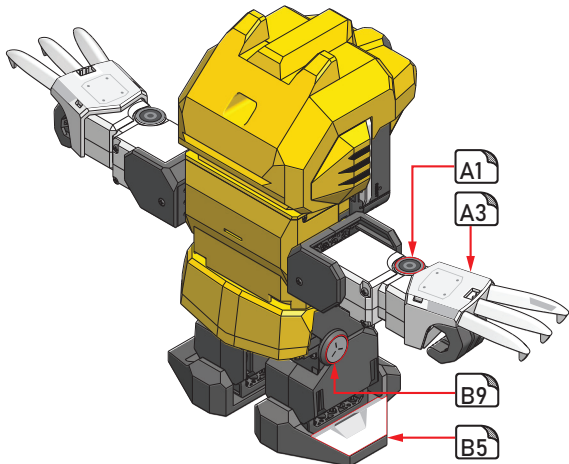
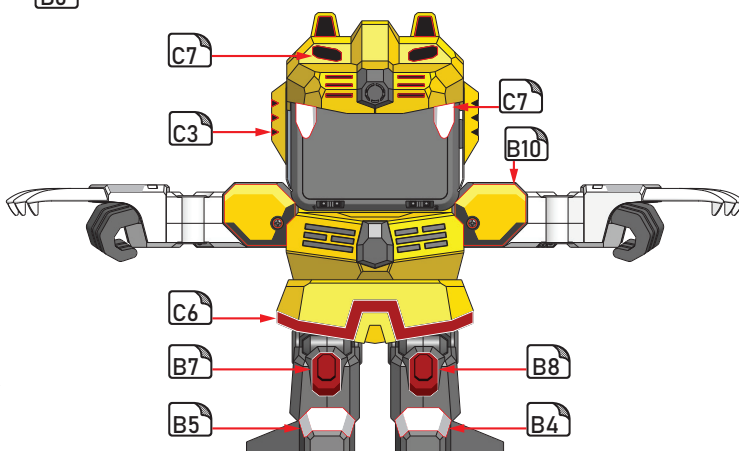
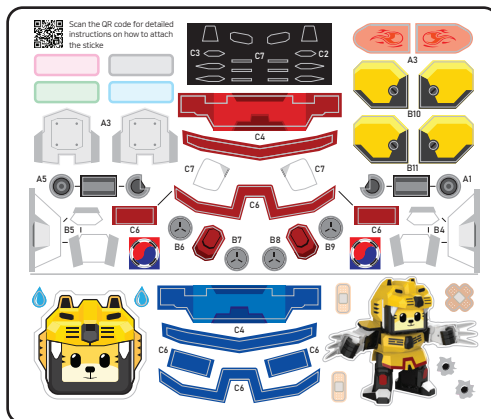
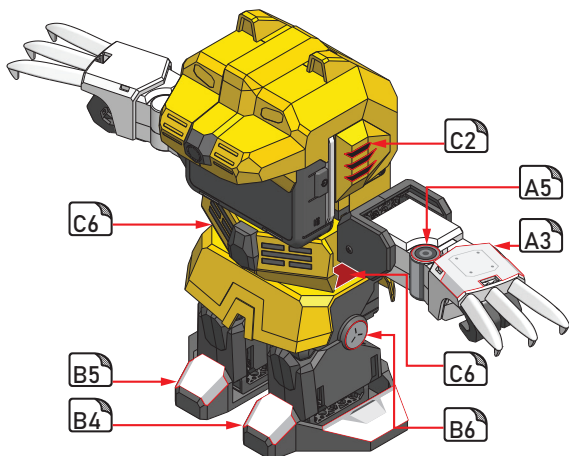

Scan the QR code for detailed instructions on how to attach the sticker.

5 Charging

The Controller (RB-100) contains a lithium polymer battery. If the battery charge drops below 30%, the controller may experience functional issues. It is advised to operate the robot only after it has been fully charged.

- (1) Connect the provided USB-C cable to a USB charger.
- (2) Initiate charging by plugging the USB-C cable into the "CHARGE/DATA" port located on the back of Tig's head.
- (3) Charging is complete when the charging indicator light turns off. Once fully charged, unplug the cable from both the charger and the controller (RB-100).

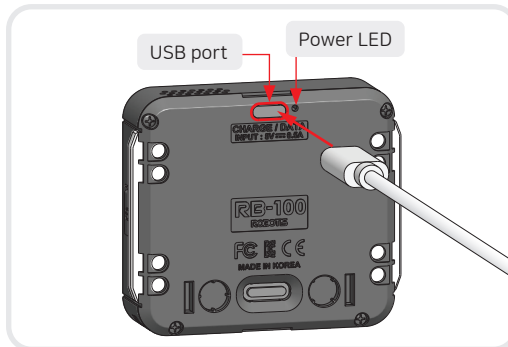

<When the controller has been disconnected for charging>

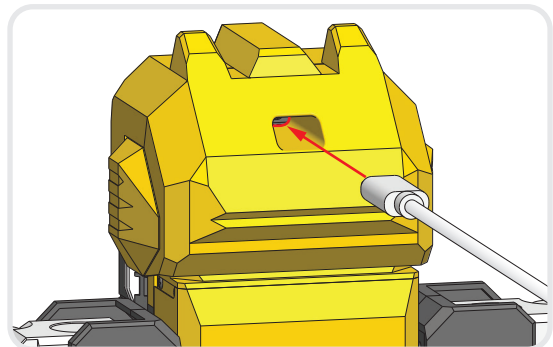

<When charging with Tig assembled>

※ For battery status, refer to the battery icon on the top-right corner of the controller's LCD screen.

6 Basic Usage

- (1) Assemble Tig according to the instructions in the assembly portion of this manual.
- (2) Press the 'power button' on the right side of the controller for 1 second to turn it on.
- (3) Once powered on, the LED will light up and Tig's face will appear on the LCD screen.
- (4) Navigate the menu using the joystick. Use the buttons at the top right corner to select or cancel options.
- (5) Removing the surrounding faceplate from the controller will allow better access to the controls in the event of difficulty.
- (6) Programming and motion editing tutorials are available through the STEAMCUP app.

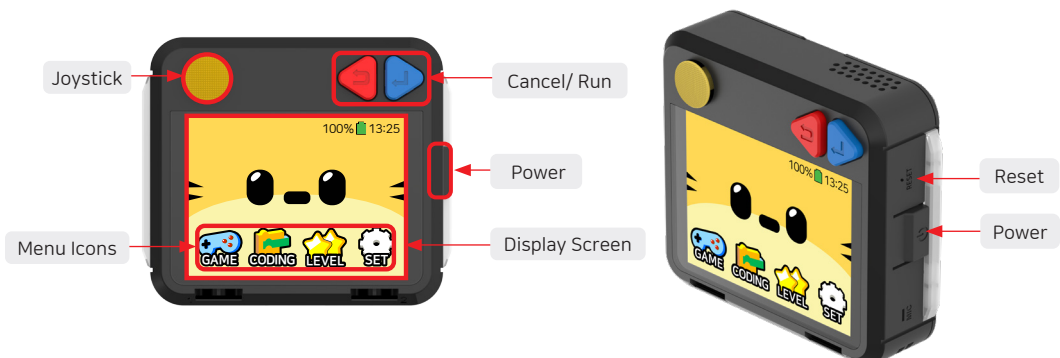

7

Installing the STEAMCUP App and Connecting the Robot

- (1) Install the STEAMCUP app by either scanning the QR code on the right or installing the app from the Google Play Store or App Store.
- (2) Follow the instructions in the app to sign up for membership.
- (3) Log in to the app and power on the controller (RB-100).
- (4) Use the device name shown below the QR code to confirm that the correct robot has been connected to the app.
- (5) In the STEAMCUP app, tap the 'Add Robot (+)' icon in the 'Robots' menu.
- (6) From the list, select the device name that was displayed in step (4).



QR for installing apps

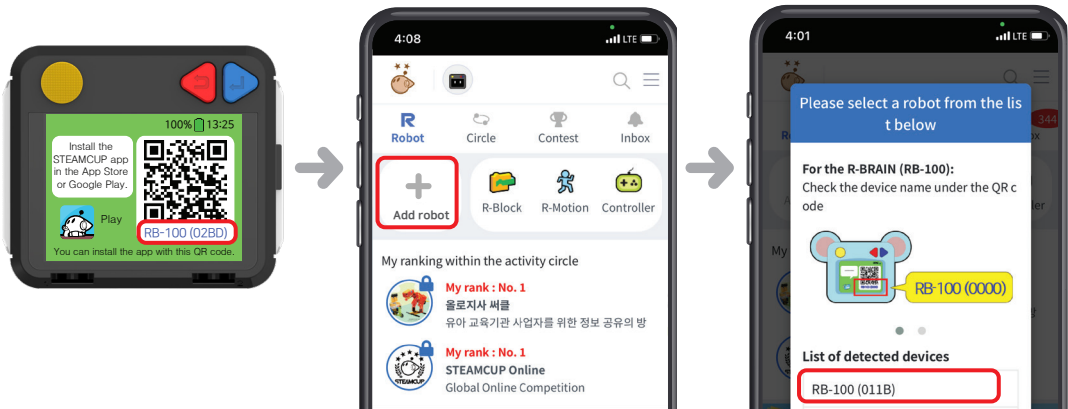

- (7) Enter the number displayed on the controller's screen into the app to finish adding the robot.

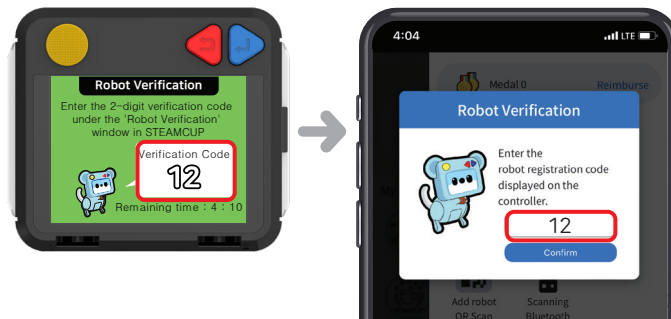

- (8) Learn how to use the joystick and the buttons to control your robot by completing the tutorial.
- (9) With the STEAMCUP app open and connected to the robot, you may be notified to install an update for your RB-100 controller. Accept the notification and wait until the update is complete before continuing.

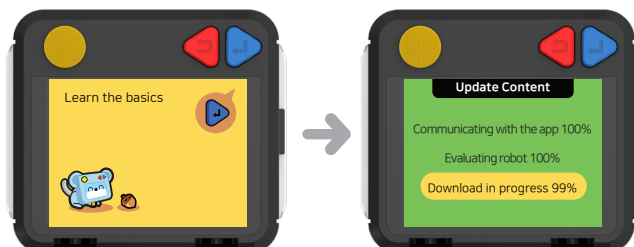

8

Assembly Check

- (1) After powering on the controller, navigate to 'Coding > Check Movement' using the controls.
- (2) Follow the instructions on the screen to verify Tig's movement.
- (3) If the movement shown on the screen is different from the actual movement of your Tig, check the Dynamixel ID number and actuator orientation for the mismatched area to solve the issue.

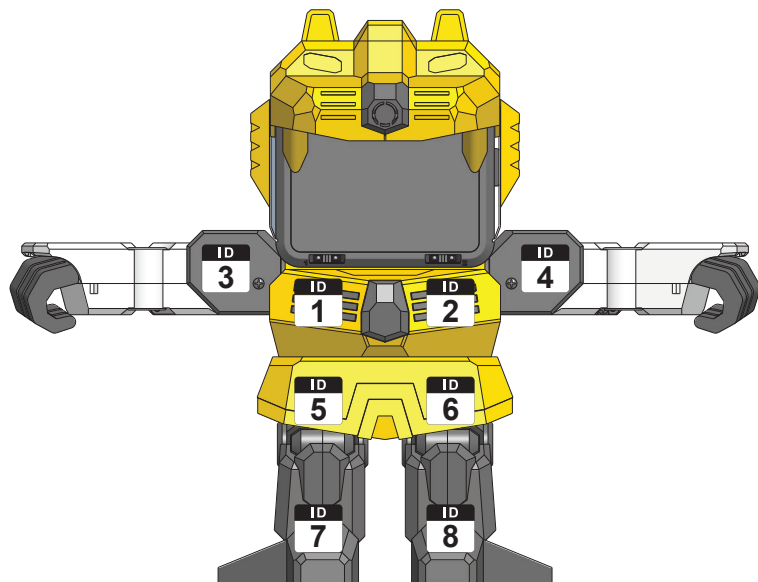
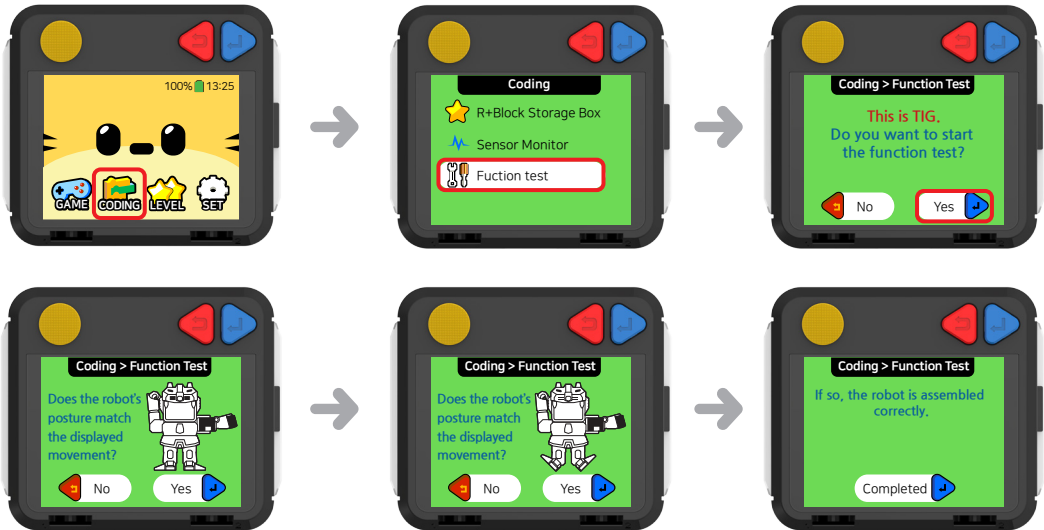

<DYNAMIXEL ID Location>

9 Wireless Controller

- (1) Turn on the robot and go to 'Settings > Connect to App with QR' in the menu to view the robot's Bluetooth address.
- (2) In the Robot tab of the STEAMCUP app, tap the controller icon in the upper right corner and connect to the Bluetooth address displayed on the robot's screen.
- (3) Use the controller's buttons to operate the robot through the STEAMCUP app.



Key	Description
U	Move Forward
D	Move Back
L	Move to the Right
R	Move to the Left
1	Get down and Get up
2	Attack 1
3	Lie down and Get up
4	Attack 2
5+L	Turn Left
5+R	Turn Right
6	Initial Pose

10 AI Control Mode



- (1) Press the menu icon (☰) on the controller to activate control mode. Use the buttons to control the robot with the stop motion, reboot joint, and AI controller functions.
- (2) By selecting the AI controller function from the menu, you can interact with the robot in a fun and user-friendly manner. Use the execution screen, voice recognition, gestures, and other features available on the execution screen.
- (3) Customization options like adding execution buttons, voice recognition, gestures, and more are available in the edit screen.



11 Tig Content Examples & Educational Materials

To access Tig content examples and educational materials, search for the name of the Circle below in the STEAMCUP app and join the Circle.

The STEAMCUP app provides a range of Tig content and educational materialsthrough the following Circles.





R-Motion Tutorial	Tig Play Coding	Tig Coding Archives
The R-motion tutorial guides users on how to use the R-motion application to create and customize motions for Tig.	This Circle introduces entertaining games utilizing Tig's multifaceted features. Download the R-Block code uploaded to this Circle onto Tig and dive into the fun!	Explore the fusion of Artificial Intelligence and Tig's smart functionalities in this Circle, which showcases diverse Tig programs, including trendy dance routines!
		

12 Changing Robot Characters

- (1) Users can switch between robot characters by choosing to display Tig's or R-GEE's face on the RB-100 controller's screen.
- (2) Remove the controller from Tig's body.
- (3) In R-GEE's menu, navigate to 'Settings > Set Detailed Option > Change Character'.
- (4) Select 'R-GEE Brain' from the list to switch the face from Tig to R-GEE.
- (5) While the R-GEE character is active, users can engage with companion functionality, missions to grow R-GEE, and fun learning and play activities associated with R-GEE.
- (6) Upon reattaching the controller to Tig's body, the character displayed on the screen will automatically revert to Tig.



※ The STEAMCUP app provides a variety of R-GEE brain content through the Circles below.

R-GEE Brain Tips	R-GEE Resource Room	R-GEE Mission Tips!	R-Block Tutorial
			

13 Participating in STEAMCUP Competitions

The STEAMCUP app hosts diverse online and offline competitions using Tig and other robots. Show off your skills through these competitions and earn various benefits and prizes.

- (1) Log in to the STEAMCUP app.
- (2) Select the STEAMCUP competition menu.
- (3) Participate in an ongoing competition by selecting a competition that suits you.
- (4) You can even create your own competitions for others to compete in.

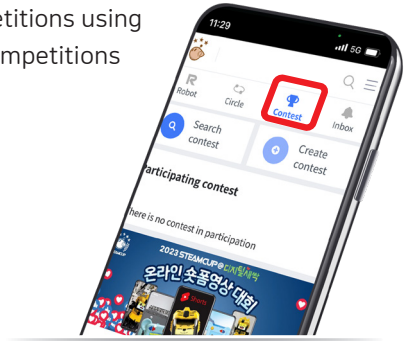

14 Precautions for Use

- (1) Refrain from disassembling or modifying this product and always provide supervision during use to prevent children from swallowing small parts.
- (2) Operating the robot on a table or other elevated surfaces introduces the possibility of the robot falling off the surface and sustaining damage. It is advisable to operate the robot on the floor to minimize the possibility of damage.
- (3) This product contains an embedded rechargeable battery. There is a risk of overheating, leakage, explosion, or fire. Do not store or operate the robot in direct sunlight or at high temperatures.
- (4) Never operate the robot in wet conditions or under water.
- (5) Be careful not to place heavy objects on the robot or apply excessive force.
- (6) Damage caused by falling from an elevated surface or by user negligence will not be covered under warranty.
- (7) Do not connect metallic objects to any of the robot's terminals.
- (8) Using a non-standard charger may cause issues with your product.
- (9) If there is a problem with the controller, press the reset button to restart.

15 Self-Diagnosis and After-Sales Service Guide

Many problems that may occur during the use of the robot can be resolved through self-diagnosis or through our A/S process.

(1) Self-Diagnosis

In the STEAMCUP app, you can identify symptoms and troubleshoot issues by selecting the "Menu > Service > Frequently Asked Questions > Tig" or by scanning the QR code on the right.



FAQ

(2) After Sales Service Information

If the problem cannot be solved by self-diagnosis, you may submit your robot for After Sales Service. To do so, visit the ROBOTIS website, fill out and submit the After Sales Service application form found under 'Customer Support > After Sales Service Application'.



Participate in the STEAMCUP challenge!



enjoy.steamcup.org

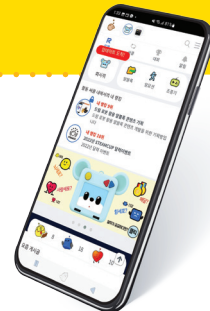

ALL RIGHTS RESERVED. Copyright © by ROBOTIS Co., Ltd.

Reproduction and modification of this book in any form or by any means without the prior consent or the written permission from the publisher is strictly prohibited.